



The Birnie Group solar class and website were created with much-appreciated support from the NSF CRCD Program under grants 0203504 and 0509886. Continuing Support from the McLaren Endowment is also greatly appreciated!

# Amorphous Silicon Solar Cells

Slides from Graduate Student Presentation by Robert Ochs in 2004 - mainly Summarizing the chapter entitled “Amorphous Silicon-based Solar Cells” by X. Deng and E. A. Schiff (2002), in *Handbook of Photovoltaic Science and Engineering*, edited by A. Luque and S. Hegedus

## Slides on these other topics might also be of interest (most collected during teaching years 2004 and 2005):

<a href="http://www.rci.rutgers.edu/~dbirnie/solarclass/BandGapandDopingLecture.pdf">http://www.rci.rutgers.edu/~dbirnie/solarclass/BandGapandDopingLecture.pdf</a>	Band Gap Engineering of Semiconductor Properties
<a href="http://www.rci.rutgers.edu/~dbirnie/solarclass/MultijunctionLecture.pdf">http://www.rci.rutgers.edu/~dbirnie/solarclass/MultijunctionLecture.pdf</a>	Multi-Junction Solar Device Design
<a href="http://www.rci.rutgers.edu/~dbirnie/solarclass/MBEgrowth.pdf">http://www.rci.rutgers.edu/~dbirnie/solarclass/MBEgrowth.pdf</a>	Molecular Beam Epitaxy
<a href="http://www.rci.rutgers.edu/~dbirnie/solarclass/TransparentConductors.pdf">http://www.rci.rutgers.edu/~dbirnie/solarclass/TransparentConductors.pdf</a>	Transparent Conductors for Solar
<a href="http://www.rci.rutgers.edu/~dbirnie/solarclass/ARCoatings.pdf">http://www.rci.rutgers.edu/~dbirnie/solarclass/ARCoatings.pdf</a>	Anti-Reflection Coatings for Solar
<a href="http://www.rci.rutgers.edu/~dbirnie/solarclass/OrganicPV.pdf">http://www.rci.rutgers.edu/~dbirnie/solarclass/OrganicPV.pdf</a>	Organic PV
<a href="http://www.rci.rutgers.edu/~dbirnie/solarclass/DSSC.pdf">http://www.rci.rutgers.edu/~dbirnie/solarclass/DSSC.pdf</a>	Dye Sensitized Solar Cells
<a href="http://www.rci.rutgers.edu/~dbirnie/solarclass/MotorPrimerGaTech.pdf">http://www.rci.rutgers.edu/~dbirnie/solarclass/MotorPrimerGaTech.pdf</a>	Working with Simple DC Motors for Student Solar Projects
<a href="http://www.rci.rutgers.edu/~dbirnie/solarclass/2005ProjectResultsindex.htm">http://www.rci.rutgers.edu/~dbirnie/solarclass/2005ProjectResultsindex.htm</a>	Examples of Previous Years' Student Solar Projects

Note: in some cases it may be possible to design custom courses that expand on the above materials (send me email!)

## Journal Publications of Some Recent Research:

(best viewed through department home index: [http://mse.rutgers.edu/dunbar\\_p\\_birnie\\_iii](http://mse.rutgers.edu/dunbar_p_birnie_iii))

## Other Birnie Group Research:

<u>Sol-Gel Coating Quality and Defects Analysis (mostly Spin Coating):</u>	<a href="http://www.coatings.rutgers.edu">http://www.coatings.rutgers.edu</a>
<u>Solar Research at Rutgers: Broader Overview</u>	<a href="http://www.solar.rutgers.edu">http://www.solar.rutgers.edu</a>
<u>Solar and Electric Vehicles System Projects (early stage emphasis)</u>	<a href="http://www.rave.rutgers.edu">http://www.rave.rutgers.edu</a>



**Professor Dunbar P. Birnie, III** ([dunbar.birnie@rutgers.edu](mailto:dunbar.birnie@rutgers.edu))  
**Department of Materials Science and Engineering**  
[http://mse.rutgers.edu/faculty/dunbar\\_p\\_birnie](http://mse.rutgers.edu/faculty/dunbar_p_birnie)

# Thin Film Amorphous Silicon Solar Cells

A sunset scene over a body of water, likely a lake or bay. The sun is low on the horizon, creating a bright orange and red glow in the sky and a reflection on the water. The water is dark with many small ducks scattered across it. In the background, there are silhouettes of trees and buildings, including a tall building on the left. The overall atmosphere is warm and serene.

14:150:491

Solar Cell Design and Processing

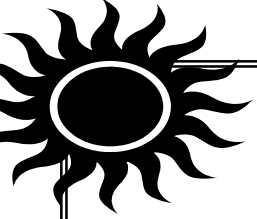

# Outline

- What is amorphous silicon?
- Atomic structure of a-Si:H
- Light induced degradation Effects
- Deposition methods
- Large-scale manufacturing
- Current state of a-Si

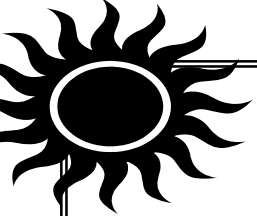

# Amorphous Silicon

- The term “amorphous” commonly applied to non-crystalline materials prepared by deposition from gases.
- Non-crystalline:
  - Chemical bonding of atoms nearly unchanged from crystals
  - Small, disorderly variation in the angles between the bonds eliminates regular lattice structure

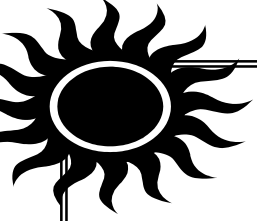

# Hydrogenated Amorphous Silicon

- In early studies of amorphous silicon, it was determined that plasma-deposited amorphous silicon contained a significant percentage of hydrogen atoms bonded into the amorphous silicon structure.
- These atoms were discovered to be essential to the improvement of the electronic properties of the material.
- Amorphous silicon is generally known as “hydrogenated amorphous silicon”, or a-Si:H.

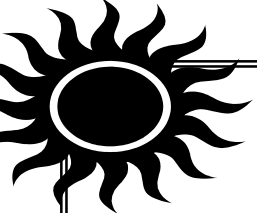

# Advantages of a-Si:H over c-Si

- Technology is relatively simple and inexpensive for a-Si:H
- For a given layer thickness, a-Si:H absorbs much more energy than c-Si (about 2.5 times)
- Much less material required for a-Si:H films, lighter weight and less expensive
- Can be deposited on a wide range of substrates, including flexible, curved, and roll-away types
- Overall efficiency of around 10%, still lower than crystalline silicon but improving

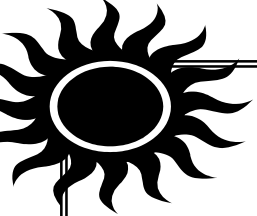

# Comparison

	a-Si/SiGe	c-Si *
Grain Size ( $\mu\text{m}$ )	Amorphous	Single Crystal
Sub. Temp. ( $^{\circ}\text{C}$ )	< 300	1000-1400
Typical Growth Methods	CVD	epitaxy + "epi-lift," "smart-cut"
Rates ( $\mu\text{m}/\text{m}$ )	0.01-0.1	1-10
Efficiencies (%)	8-13	~18
Cell Thk. ( $\mu\text{m}$ )	0.3-0.7	5-50
Cell Type	drift, stacked	diffusion
Pros	very high absorption, $E_g$ tailoring	infrastructure, synergy with IC industry
Cons	instable (SWE), poor red collection	3-step processes, large area difficult

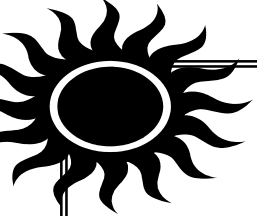

# Atomic Structure

- Same basic structure shared by crystalline and amorphous silicon
- For amorphous silicon, several percent of silicon atoms make covalent bonds with only 3 neighboring silicon atoms, the remaining electron bonds with a hydrogen atom
- 2 principal configurations for hydrogen:
  - Dilute: a particular hydrogen atom is about 1 nm away from any other hydrogen atom
  - Clustered: there are two or more hydrogen atoms in close proximity
  - The density of hydrogen atoms depends on how the material is made



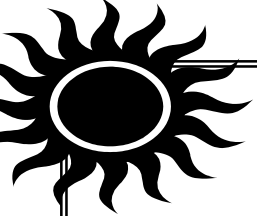

# Chemical Bonding Defects

- Affect the electronic properties of the material
- The D-center, or dangling silicon bond, is the most influential defect on electronic properties
- The defect density has been shown to increase, then stabilize, with increasing illumination time, or “light soaking”

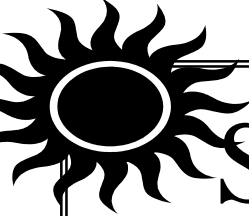

# Staebler-Wronski Effect

- There is a significant decline in the efficiency of a-Si:H solar cells during first few hundred hours of illumination
- A-Si:H modules reach steady-state after about 1,000 hours of steady illumination
- Seasonal variations in conversion efficiency were noticed. For a specific module studied:
  - Up to 20 deg. C., there is an increase in efficiency with temperature
  - c-Si has the opposite, where there is a decrease in efficiency with temperature

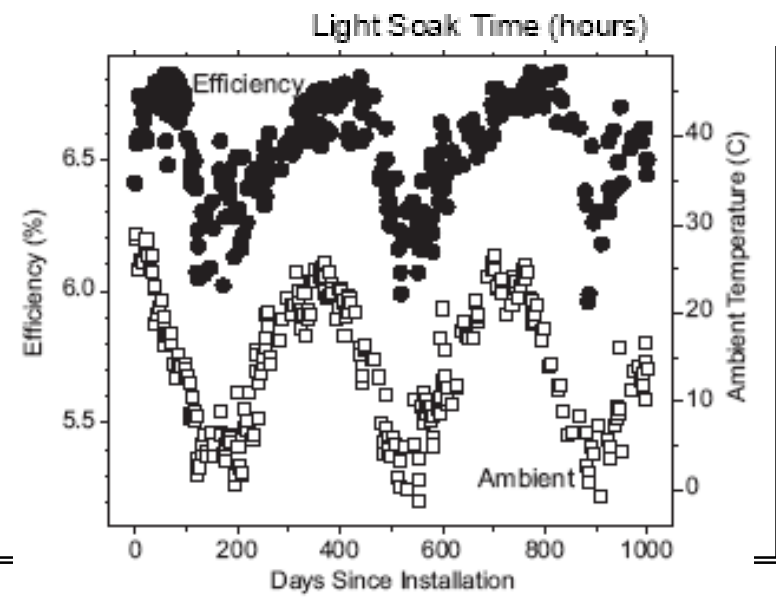
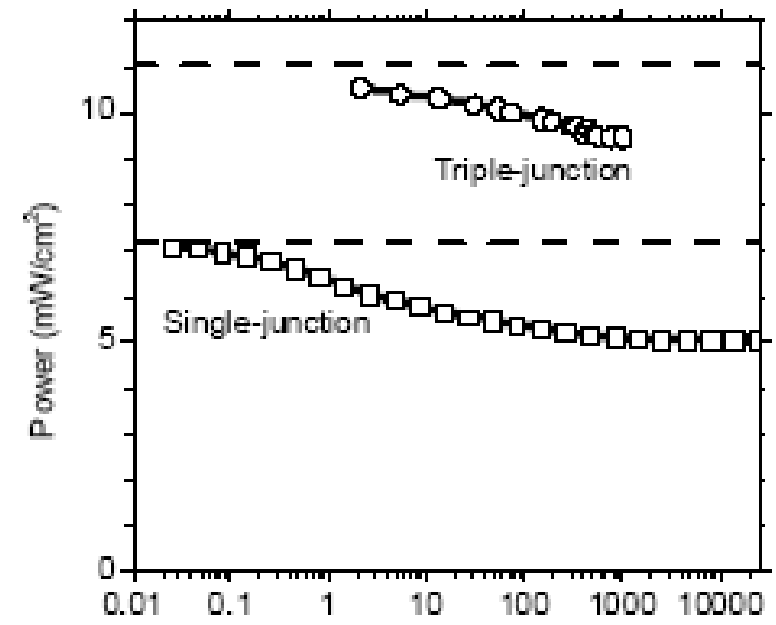

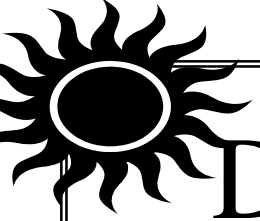

# Defect Density and the Staebler Wronski Effect

- Researchers believe that the increase in defect density with light soaking is the principal cause for the Staebler Wronski effect
- Defect density is the dangling bond, which occurs when hydrogen does not bond to the fourth silicon bond
- Since defect density increases with illumination, it is believed that illumination provides the energy required to push hydrogen away from the fourth silicon bond, creating a dangling bond
- Also, since it has been found that the density of hydrogen in the film is determined by how the film is made, it may be possible to reduce the Staebler Wronski effect with manufacturing techniques

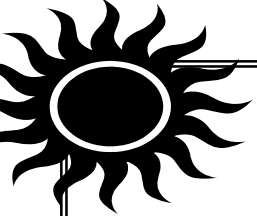

## Staebler Wronski (cont.)

- Performance degrades during illumination because defect density (dangling bonds) increases, which will capture electrons created by photons
- Researchers have found ways to reduce the effect by incorporating fluorine in the gas mixture during production
- Fluorine bonds tighter to silicon than hydrogen, and is less mobile in the a-Si network
- Fluorinated a-Si cells show much better stability under light soaking
- Further research into the deposition process will further improve the fluorinated a-Si cell

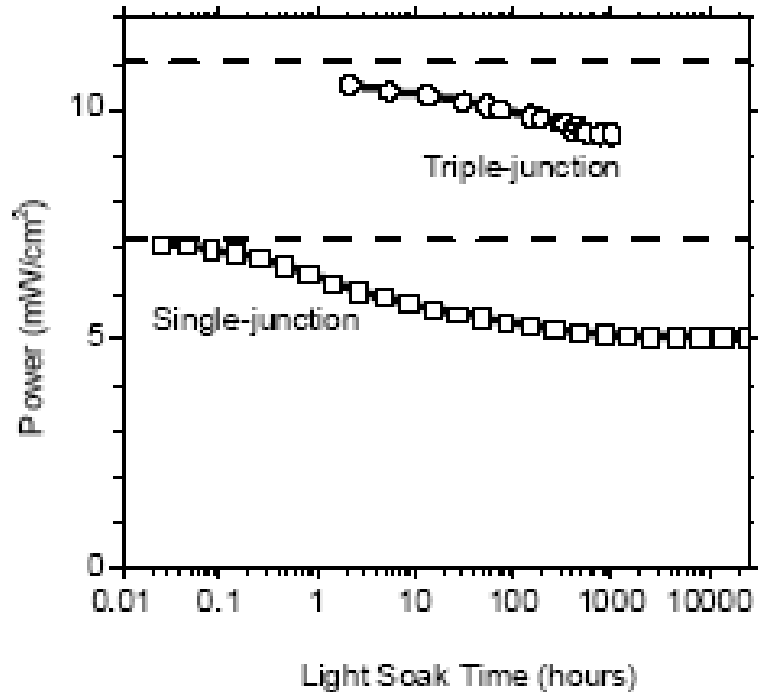

← Degradation of power with illumination time

Increase of defect density with illumination time

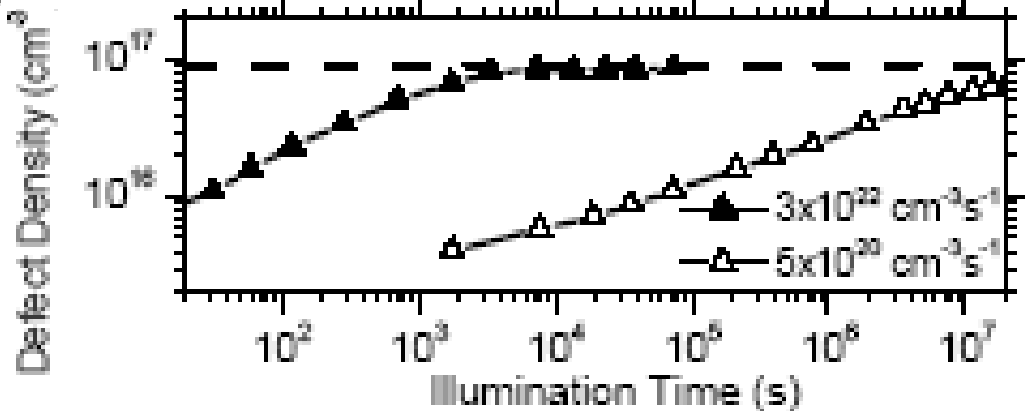
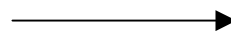

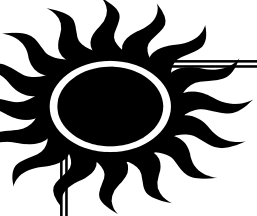

# Energy Bands

- Perfect crystals,  $E_G = E_C - E_V$
- Amorphous semiconductors have exponential distributions of conduction and valence bands
- There is no single procedure for locating the band edges
- The bandgap can be approximated by analyzing measurements of the optical absorption coefficient  $\alpha(h\nu)$

$$\alpha(h\nu) = (A/h\nu)(h\nu - E_T)^2$$

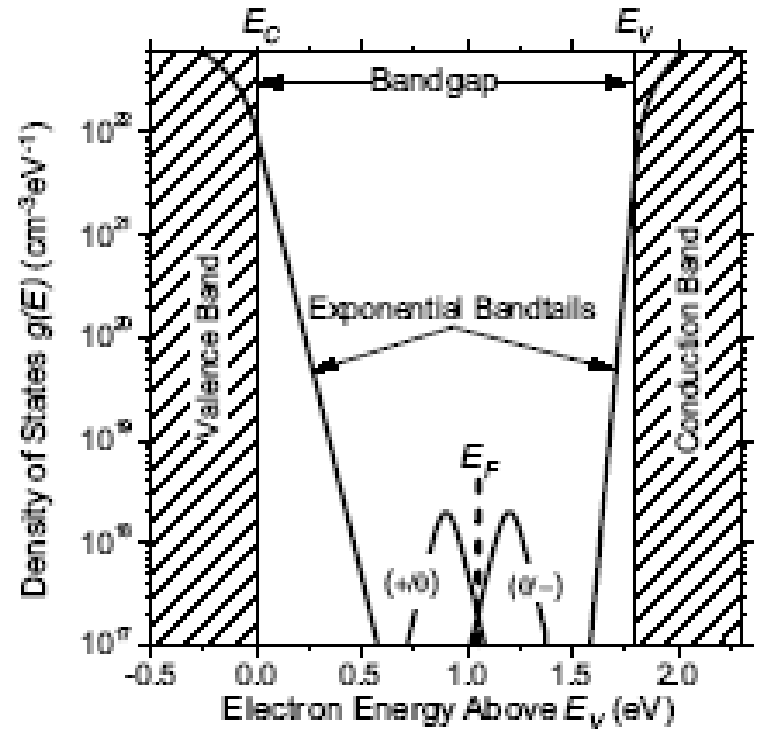

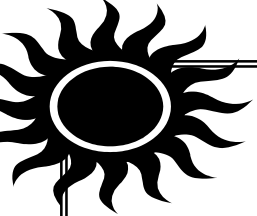

# Doping a-Si:H

- Doping with phosphorous in c-Si raises the fermi energy level by adding an extra electron
- In a-Si:H, P atoms bond only to 3 silicon neighbors, leaving 2 electrons paired in “s” atomic orbitals which do not participate in bonding. This is a chemically advantageous
- It was found that occasionally, P can bond in a-Si:H as it does in c-Si, where four electrons are shared with 4 neighboring Si atoms, but a negatively charged dangling bond is also created
- Therefore, doping in a-Si:H is inefficient
  - Most dopant atoms do not contribute a free electron and do not raise the fermi energy level
  - For each dopant that does contribute an electron, there is a balancing Si dangling bond to receive it

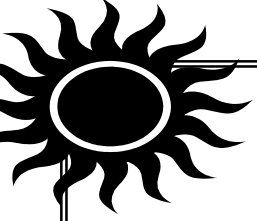

# Alloying with Additional Elements

- Alloying with elements, such as Ge, can be accomplished during film production
- The resulting alloys have wide ranges of bandgaps
- This can be very useful for creating multijunction pin cells, where the narrow bandgap of a-SiGe allows for increased absorption of lower energy photons



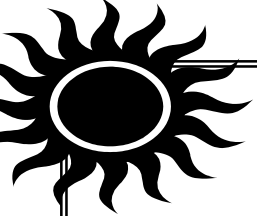

# Multijunction Cells

- Cell stacking suited for amorphous cells
  - No need for lattice matching, as in c-Si
  - Bandgaps can be readily adjusted by alloying
- Multijunction a-Si based cells have higher solar conversion efficiency than single junction cells
- Most commercially produced a-Si based cells are multijunction type

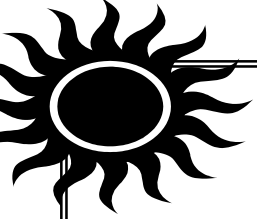

# Spectrum Splitting

- Top junction has higher bandgap than bottom junction, top junction absorbs higher energy photons, and passes by the lower energy photons for the bottom junction to absorb
- Semiconductors with wide ranges of bandgaps can be created by alloying
- By stacking any amount of cells by decreasing bandgap, much of the incoming light can be absorbed and converted

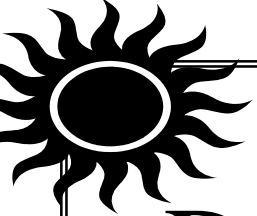

# Deposition of Amorphous Silicon

- Silane-based ( $\text{SiH}_4$  gas) glow discharge induced by RF voltages, or plasma enhanced chemical vapor deposition
  - 13.56 MHz excitation
  - VHF
  - Remote MW
- Hot-wire catalytic deposition

# RF PECVD

1. Silicon containing gas,  $\text{SiH}_4$  and  $\text{H}_2$  flows into a vacuum chamber
2. RF power applied across two electrode plates
3. A plasma will occur at a given RF voltage for a specific range of gas pressures
4. Plasma excites and decomposes the gas and generates radicals and ions
5. Thin hydrogenated silicon films grow on heated substrates mounted on the electrodes

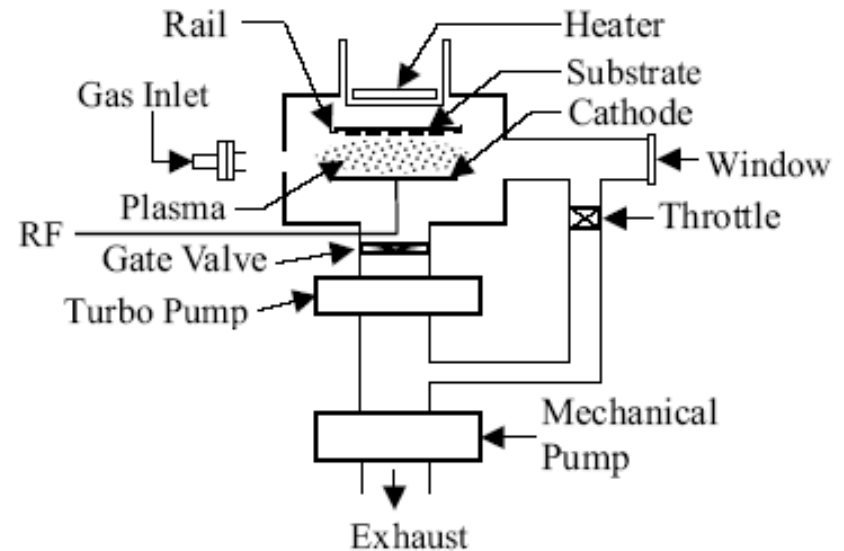

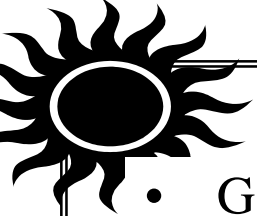

# Deposition Conditions

- Gas pressure
  - Higher for preparing microcrystalline films
  - Lower for uniform deposition
- RF Power
  - Higher power for higher deposition rate
  - Above 100 mW/cm<sup>2</sup>, rapid reactions create silicon polyhydride powder that contaminates the growing Si film
- Substrate temperature
  - Lower T, more H incorporated in the film, increases the bandgap of a-Si:H
    - Below 150 deg. C., makes the powder formation worse
  - Higher T, less hydrogen is incorporated and the bandgap is slightly reduced
    - Above 350 deg. C., the quality of the material degrades due to loss of hydrogen and increasing defect density (dangling bonds)
- Electrode spacing
  - Smaller spacing for uniform deposition
  - Larger spacing makes maintaining plasma easier

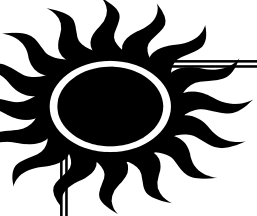

# Hydrogen Dilution

- Dilution accomplished by mixing in hydrogen with the silane gas mixture
- Strong dilution has been found to reduce the defect density and improve the stability of the material against light-soaking effects
- If dilution is increased significantly, the thin silicon films will become microcrystalline

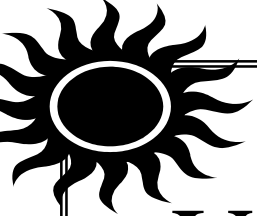

# VHF Glow Discharge Deposition

- It has been determined that the deposition rate of a-Si films increases linearly with plasma excitation frequency
- High quality a-Si films have been created at rates exceeding 1nm/s without making contaminating polyhydride powder
- Challenges for large scale production include adapting the technique to larger electrode sizes

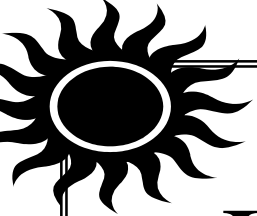

# Indirect Microwave Deposition

- When microwave plasma is in direct contact with substrate, the deposited films have very poor optoelectronic properties
- By exciting a carrier gas such as He or Ar, the carrier gas then excites the silane gas
- This method shows promise for very high deposition rate, 50 Å/s, in the future





# Hot-Wire Glow Discharge Deposition

- Silane gas is catalytically excited or decomposed into radicals/ions by a superheated metal filament (1800-2000 deg. C.)
- Silicon radicals diffuse inside the chamber and deposit onto the heated substrate
- It has been found that HWCVD deposited a-Si films show lower H content and improved light stability when compared with RF PECVD films
- Challenges
  - HW can deposit at a very high rate (150-300 A/s)
  - Uniformity of HW films still poorer than RF films
  - Filament material needs to be improved to reduce maintenance time
  - HW solar cells perform poorer than RF produced cells

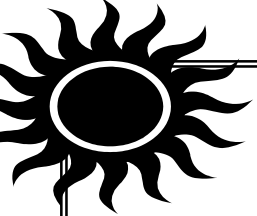

# Large-Scale Production

- Continuous “roll to roll” manufacturing processes developed by Energy Conversion Devices, Inc.
- A “roll” of flexible substrate (stainless steel) is unrolled and fed into the manufacturing process, and rolled back up at the end
- Four continuous processes:
  - Substrate washing
  - Sputter deposition of back-reflector
  - a-Si semiconductor deposition
  - ITO top electrode deposition
- Large roll can be cut into different sizes to meet application needs

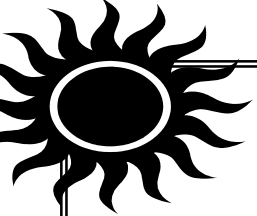

# Pros/Cons of Roll-to-Roll

- Advantages:
  - Product is lightweight and flexible
  - Product can be cut to different sizes after manufacture
  - High production yield can be maintained
- Disadvantages:
  - Labor intensive
  - The four steps are currently not integrated into one machine; each step requires drastically different working pressures
  - Cutting process is labor intensive

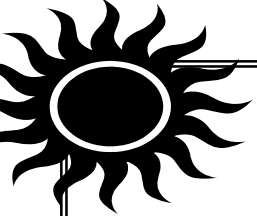

# Current State of a-Si

- a-Si cells have been made with 15.2% initial efficiency and 13% stable efficiency
- Rapid deposition processes are being refined so that high rate, high quality can be achieved
- Research into light degradation remedies will provide for cells with efficiencies comparable with c-Si cells
- New applications for a-Si cells are being sought such as building-integrated PV, space power, consumer electronics, grid integration, and large scale power generation