

# Selective Faithfulness and Voicing Assimilation\*

Sarah E. Murray, Rutgers University  
HUMDRUM, 30 April 2006

[semurray@rutgers.edu](mailto:semurray@rutgers.edu)

## 1. Introduction: Headed Syllable Constituents and Selective Faithfulness Theory

### (1) *Overview of Selective Faithfulness Theory*

#### (a) Representation:

- (i) Every syllable constituent has a (rigidly defined) head  
(*Headed Syllable Constituents Hypothesis* (=: HeSC))

#### (b) Constraints:

- (i) Faithfulness to heads (e.g., ‘onset head’)
- (ii) No faithfulness to anything else

#### (c) Other Assumptions

- (i) Autosegmentalism, full specification, equipollent voicing feature
- (ii) Positional faithfulness to onset heads to predict the direction of assimilation (Beckman 1998 and Lombardi 1999)
- (iii) Voicing faithfulness is split into faithfulness to each feature value  
(*Split Faithfulness Hypothesis*)
- (iv) Autosegmentally defined markedness constraints which drive assimilation and neutralization

#### (d) Results:

- (i) Predicts monomorphemic tautosyllabic voicing agreement in obstruent-obstruent clusters (*Absolute Assimilation*<sup>1</sup>)
- (ii) Predicts agreement/disagreement of obstruent-sonorant clusters
- (ii) Accounts, more generally, for known range of voicing assimilation and neutralization patterns
- (iii) Avoids the Majority Rules problem

### (2) *Structure of the rest of this talk*

Section Two: Syllable Internal Voicing Agreement

Section Three: Core Constraints and Implementation

Section Four: Headed Syllable Constituents Hypothesis

Section Five: Predictions: Typology and (NO) Majority Rules

---

\* Many thanks go to Qualifying Paper committee, Paul de Lacy, Alan Prince, and Bruce Tesar for their helpful (and plentiful) comments and discussion. A special thanks goes to Gary Toops for discussion of the Czech data. Still more thanks go to Akin Akinlabi, Daniel Altshuler, Jane Grimshaw, John Kingston, John Manna, Mike O’Keefe, Lisa Selkirk, Roger Schwarzschild, William Starr, and the audience at RULing 1 for comments and discussion on this topic and earlier drafts. All errors are, of course, my own.

<sup>1</sup> I thank Paul de Lacy for the suggestion of this terminology

## 2. Syllable-Internal Voicing Agreement

- (3) *Distribution of voicing in clusters*  
 (a) Agreement in obstruent-obstruent clusters (and no disagreement)  
 (b) Agreement in sonorant-sonorant clusters (and no disagreement)  
 (c) Agreement in obstruent-sonorant clusters  
 (d) Disagreement in obstruent-sonorant clusters (solely by markedness)
- (4) *Absolute Assimilation*  
 No language has surface obstruent voicing disagreement within a constituent:  
 i.e.  $\text{[b.ta.]}$ ,  $\text{[z.ta.]}$  (Greenberg 1978, Kehrein & Golston 2004)
- (5) *But, why?*  
 Given ROTB and general faithfulness, why do no obstruent-obstruent clusters differ in voicing on the surface? Why doesn't /bta/ →  $\text{[b.ta.]}$ ?
- (6) *Selective Faithfulness*  
 Clusters are faithful in voicing to one and only one of their members — their head.
- (7) **Stipulation: The definition of head (will be returned to in Section Four)**
- (8) *Definition of Head Position*<sup>2</sup>  
 (a) Head(Onset) → the least sonorous member of the onset  
 (b) Head(Coda) → the least sonorous member of the coda
- (9) *Illustration of Head Definitions* (heads are bolded): [.ska.] [.ksa.] [.sna.] [.na.]
- (10) *Faithfulness only to the head*  
 If there is *only one* member to whom the (monomorphemic tautosyllabic) cluster is faithful, given a markedness pressure to reduce the number of specifications (e.g., \*SPECIFY(voice)), the cluster will necessarily agree.
- (11) *Absolute Assimilation: Illustration* (heads are circled)

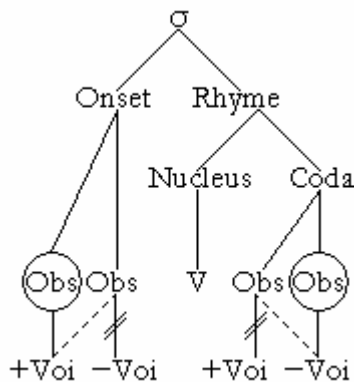

• Informally, this diagram shows the significance of heads: In Selective Faithfulness Theory, there is no faithfulness (to voice) in non-heads, so, given the markedness pressure to minimize voicing specifications, non-heads obligatorily take on the voicing value of the head of their constituent<sup>3</sup> (see below for a constraint-based argument). [NB: Heads are bolded in tableaux, not circled]

<sup>2</sup> The nucleus has a head, but discussion of this is not relevant here.

<sup>3</sup> Barring, of course, other markedness pressures, like voicing neutralization. In this case, a markedness constraint (\*VOIOBS, or the like) would outrank faithfulness to the head and both the head and the non-head(s) would devoice. See Section Four for discussion within Selective Faithfulness Theory.

### 3. Core Constraints of Selective Faithfulness (for Voicing) and Implementation





- (12) *Split Faithfulness Hypothesis*  
 There are languages which *independently* regressively spread either [-VOICE] (Ya:thê, Mekkan Arabic) or [+VOICE] (Ukrainian) (Butska 1998, Wetzels & Mascaró 2001). Faithfulness to voice must be split to each value to account for these patterns. [See Appendix One for discussion and rankings for these two languages.]
- (13) *Selective Faithfulness for voicing*
- (a) There is only voicing faithfulness to the underlying specification of heads.
  - (b) There is stringent positional faithfulness (Beckman 1998 and Lombardi 1999)
  - (c) There is split faithfulness.
- (14) *Core Faithfulness Constraints for voicing assimilation*
- (a) IDENT-HEAD([+VOICE]) (=: IH[+V])  
 “Heads are [+VOICE] if their input correspondents are”  
 For all segments  $x, x'$  s.t.  $x \in \text{Input}, x' \in \text{Output}$ , and  $x'$  is syllabified in a head position, if  $x'$  is the output correspondent of  $x$  and  $x$  is [+VOICE], then  $x'$  is [+VOICE].
  - (b) IDENT-HEAD([-VOICE]) (=: IH[-V])  
 “Heads are [-VOICE] if their input correspondents are”  
 For all segments  $x, x'$  s.t.  $x \in \text{Input}, x' \in \text{Output}$ , and  $x'$  is syllabified in a head position, if  $x'$  is the output correspondent of  $x$  and  $x$  is [-VOICE], then  $x'$  is [-VOICE].
  - (c) IDENT-HEAD(ONSET) ([+VOICE]) (=: IHO[+V])  
 “Onset heads are [+VOICE] if their input correspondents are”  
 For all segments  $x, x'$  s.t.  $x \in \text{Input}, x' \in \text{Output}$ , and  $x'$  is syllabified as the head of an onset, if  $x'$  is the output correspondent of  $x$  and  $x$  is [+VOICE], then  $x'$  is [+VOICE].
  - (d) IDENT-HEAD(ONSET) ([-VOICE]) (=: IHO[-V])  
 “Onset heads are [-VOICE] if their input correspondents are”  
 For all segments  $x, x'$  s.t.  $x \in \text{Input}, x' \in \text{Output}$ , and  $x'$  is syllabified as the head of an onset, if  $x'$  is the output correspondent of  $x$  and  $x$  is [-VOICE] then  $x'$  is [-VOICE].
- (15) *Core Markedness Constraints for voicing assimilation*
- (a) \*LINK[+VOICE] autosegment (=: \*LINK[+V])  
 Assess one violation for each obstruent in head position linked to a [+VOICE] autosegment.
  - (b) \*SPECIFY[VOICE] (=: \*SPEC[V])  
 Assess one violation for each [VOICE] autosegment.

### 3.1 Absolute Assimilation

(16) *Selective Faithfulness predicts Absolute Assimilation*



Because there is no faithfulness to non-heads, pressure to reduce the number of voicing specifications causes *Absolute Assimilation*.

(17) *Absolute Assimilation of underlying voicing disagreement in /zta/*

/zta/	*SPEC[V]	IHO-	IH-	*LINK[+V]
1.  [zta.]	1			
2. $\sim$  [zda.]	e <sub>1~1</sub>	<b>W</b> <sub>0~1</sub>	<b>W</b> <sub>0~1</sub>	<b>W</b> <sub>0~1</sub>
3. $\sim$  [sda.]	<b>W</b> <sub>1~2</sub>	e <sub>0~0</sub>	e <sub>0~0</sub>	e <sub>0~0</sub>
4. $\sim$  [zta.]	<b>W</b> <sub>1~2</sub>	<b>W</b> <sub>0~1</sub>	<b>W</b> <sub>0~1</sub>	<b>W</b> <sub>0~1</sub>

• The tableau in (17) shows that underlying /zta/ will *always* assimilate to [zta.], as all of the other candidates are harmonically bounded by candidate in (1).

(18) *Absolute Assimilation of underlying voicing disagreement in /sda/*

/sda/	*SPEC[V]	IHO+	IH+	*LINK[+V]
1.  [zda.]	1			1
2. $\sim$ [sta.]	e <sub>1~1</sub>	<b>W</b> <sub>0~1</sub>	<b>W</b> <sub>0~1</sub>	<b>L</b> <sub>1~0</sub>
3. $\sim$  [zta.]	<b>W</b> <sub>1~2</sub>	e <sub>0~0</sub>	e <sub>0~0</sub>	e <sub>1~1</sub>
4. $\sim$  [sda.]	<b>W</b> <sub>1~2</sub>	<b>W</b> <sub>0~1</sub>	<b>W</b> <sub>0~1</sub>	<b>L</b> <sub>1~0</sub>

• The tableau in (18) shows that underlying /sda/ will *always* assimilate to *either* [zda.], (when IHO+ >> \*LINK[+V] or IH+ >> \*LINK[+V]) or to [sta.], (when \*LINK[+V] >> IHO+, IH+). Note that candidate 4 is harmonically bounded by candidate 2.

• Crucially, there can be no \*z constraint, else the generalization does not hold

(19) *Disagreement in tautosyllabic clusters?*

Any deviation from this pattern of absolute assimilation will be caused by a markedness constraint which prohibits the output of the assimilation. For example, many languages permit tautosyllabic voicing disagreement in obstruent-sonorant clusters.

### 3.2 Tautosyllabic Voicing Disagreement

(20) *Obstruent-Sonorant Clusters*

Many languages preserve input voicing disagreement in obstruent-sonorant clusters; e.g. /sno/ → [sno.] and /tre/ → [tre.]

(21) *Not Faithfulness – Only Markedness*

Selective Faithfulness theory predicts tautosyllabic obstruent-sonorant voicing disagreement *with no additional faithfulness constraints*.

- (22) \*[-voi] [+son] (=:\*s<sub>on</sub>)  
 Assess one violation for each segment associated with both [-voi] and [+son]

- (23) *Obstruent-Nasal Clusters can disagree in voicing*

/sno/	*s <sub>on</sub>	*SPEC[V]	*LINK[+V]	IHO-	IH+	IH-
1.  [sno.]		2	1			
2. ~[.sno.]	<b>W</b> <sub>0~1</sub>	<b>L</b> <sub>2~1</sub>	<b>L</b> <sub>1~0</sub>	e <sub>0~0</sub>	e <sub>0~0</sub>	e <sub>0~0</sub>

(The markedness constraint against voiceless sonorants prevents absolute assimilation)

- (24) *Obstruent-Liquid (or -Glide) Clusters can disagree in voicing*

/tre/	*s <sub>on</sub>	*SPEC[V]	*LINK[+V]	IHO-	IH+	IH-
1.  [tre.]		2	1			
2. ~[.tre.]	<b>W</b> <sub>0~1</sub>	<b>L</b> <sub>2~1</sub>	<b>L</b> <sub>1~0</sub>	e <sub>0~0</sub>	e <sub>0~0</sub>	e <sub>0~0</sub>

(The markedness constraint against voiceless sonorants prevents absolute assimilation)

### 3.3 Summary: Constraint Restrictions and Typological Predictions of Heads

- (25) *What you can can't have<sup>4</sup> (the strong hypothesis)*  
 Selective faithfulness precludes a number of markedness constraints  
 e.g., \*b, \*d, \*bd, etc

- (26) *What you can have (the strong hypothesis)*  
 \*SPEC[V], \*SPEC[+V], \*LINK[V], \*LINK[+V], \*s<sub>on</sub>

- (27) *Absolute Assimilation*  
 Selective Faithfulness theory predicts all clusters should agree in voicing, with only one exception:

- (i) markedness constraints which disprefer the output of assimilation  
 e.g. to not devoice sonorants  
 /sno/ → [.sno.] and /tre/ → [.tre.]

- (28) *Assimilation to the head*  
 All within-constituent voice assimilation should be to the least sonorous member of that constituent, the head, with the only exception being caused by markedness<sup>5</sup>:

- (i) Markedness constraints (e.g., dominance of \*LINK[+V])  
 e.g. /ba/ → [.pa.], /sda/ → [.sta.]  
 /ab/ → [.ap.], /ads/ → [.ats.]

<sup>4</sup> Thanks to Jane Grimshaw for drawing my attention to this crucial issue

<sup>5</sup> There may also be interactions with with faithfulness to the stem. This may require a dynamically defined head, where the head could either be the least sonorous member of the constituent, or the (least sonorous) member from the stem. This issue requires more investigation, and some hard to come by data

#### 4. Headed Syllable Constituents (HeSC)

- (29) *Constituent Heads*  
 (a) Each syllable constituent has a head  
 (Related to ideas in Charm and Government Phonology, Dependency Phonology, Span Theory).  
 (b) The head is the only locus of voicing faithfulness.  
 (c) The head position is rigidly determined.
- (30) *Definition of Head Position*<sup>6</sup>  
 (a) Head(Onset) → the least sonorous member of the onset  
 (b) Head(Coda) → the least sonorous member of the coda
- (31) *Illustration of Head Definitions* (heads are bolded)  
 [.ska.] [**ks**a.] [.sna.] [**na**.]

#### 4.1 Definition of Onset Head: Evidence from Czech.

- (32) *Why define heads as the ‘least sonorous’?*  
 Czech has obstruent-obstruent clusters where the least sonorous member controls assimilation; evidence: voicing distinction in input, within a constituent.
- (33) *The Czech obstruent* [ř]  
 Czech [ř] is an obstruent trill (see Ketner 2005), and contrasts with [r], the sonorant trill. [ř] and [r] are in complementary distribution<sup>7</sup>; [ř] occurs only in assimilation contexts and word-finally (Czech has coda voicing neutralization). (Czech data from Kučera 1961, Palková 1994, and Ketner 2005)
- (34) [ř] contrasts with [r]  
 (a) [řa.da.] ‘line, row’  
 (b) [ra.da.] ‘advice’
- (35) [ř] does not contrast with [ř̥]  
 (a) [tř̥i.] ‘three’, \*[tř̥i]  
 (b) [dř̥i:ve.] ‘soon(er)’, \*[dř̥i:ve]  
 (c) [tvař̥.] ‘face (nom.sg.)’ \*[tvař̥.]  
 (d) [ře.ka.] ‘river (nom.sg.)’ \*[ř̥e.ka.]  
 (e) [na:řek.] ‘lamentation (nom.sg.)’ \*[na:ř̥ek.]
- (36) *Allophony of [ř] and [ř̥]*  
 /ř/ → [ř], [ř̥] (word finally, as a result of assimilation)

<sup>6</sup> The nucleus has a head, but discussion of this is not relevant here.

<sup>7</sup> There is no [r]

- (37) *Danger! ROTB: what happens to /ř/?*
- (a) /ř/ → [ř], [ʃ] requires /řeka/ → [.ře.ka.] and /tvař/ → [.tvař.] (positional markedness)
- (b) /ř/ → [ʃ] requires faithfulness to manner
- (38) *Alternations*
- (a) [na:řek] ‘lamentation (nom.sg.)’
- (b) [na:řki] ‘lamentations (nom.pl.)’
- (c) [keř] ‘bush’
- (d) [keře] ‘bush (gen.sg.)’
- (e) [.tvař.] ‘face (nom.sg.)’
- (f) [.tva.ře.] ‘face (f.dat.sg.)’
- (g) [.tvař.sina.] ‘son’s face’
- (39) *Least Sonorous member is the head*
- (a) [řkouce] ‘saying (pres.part)’ /řk+-ouce/
- (b) [křeči] ‘cramp (dat.sg.)’
- (c) /tak/ + /řk/+ouce/ → [takřkouce] ‘thus saying’
- (d) /tak/ + /řečeni/ → [tagřeci] ‘so called’
- (40) *“progressive” tautosyllabic voicing*
- (a) /při/ → [při] ‘near’
- (b) /středa/ → [středa] ‘Wednesday’
- (c) /tři/ → [tři] ‘three’
- The least sonorous member is the onset-head, so [ř] devoices. IDENT-HEAD(ONSET) triumphs.
- (41) *Heterosyllabic regressive voicing assimilation*
- (a) /arab/+ski/ → [arap.ski.] ‘Arabic’
- (b) /moř/+ski/ → [.moř.ski.] ‘oceanic’
- (c) /přes/+řadou/ → [přez. řa.dou.] ‘across (a/the) line’
- IDENT-HEAD(ONSET) triumphs.
- (42) *Onset head as the ‘least sonorous’ explains:*
- (a) progressive tautosyllabic voicing assimilation and
- (b) regressive heterosyllabic voicing assimilation
- (43) *Alternative 1: Why not say that [ř] has weak faithfulness to [voice] or (ignoring Richness of the Base!!) say that it has no underlying [voice] specification?*
- [+voice] does spread from [ř] in regressive voicing.
- (44) *Alternative 2: Lombardi (1999): The released obstruent is the ‘head’*
- (a) Incorrectly predicts /tři/ → \*[dři.]

- (45) *Onset Head Driven Assimilation*  
 Czech has both progressive and regressive Heterosyllabic regressive assimilation.  
 But, both are *onset-head driven assimilation*.

(46) Czech: /přes/+/řadou/ → [přez.řa.dou.] ‘across (a/the) line’

/přes/+/řadou/	*SPEC[V]	IHO-	IHO+	IH+	*LINK[+V]	IH-
1. [přez.řa.dou.]	3				3	1
2. ~[přes.řa.dou.]	e <sub>3~3</sub>	e <sub>0~0</sub>	W <sub>0~1</sub>	W <sub>0~1</sub>	L <sub>3~1</sub>	L <sub>1~0</sub>
3. ~[přes.řa.dou.]	W <sub>3~4</sub>	e <sub>0~0</sub>	e <sub>0~0</sub>	e <sub>0~0</sub>	L <sub>3~2</sub>	L <sub>1~0</sub>
4. ~[přes.řa.dou.]	W <sub>3~5</sub>	e <sub>0~0</sub>	e <sub>0~0</sub>	e <sub>0~0</sub>	L <sub>3~2</sub>	L <sub>1~0</sub>
5. ~[břez.řa.dou.]	e <sub>3~3</sub>	W <sub>0~1</sub>	e <sub>0~0</sub>	e <sub>0~0</sub>	W <sub>3~4</sub>	W <sub>1~2</sub>

NB: The shaded rows are harmonically bounded, included to show violations

- Selective Faithfulness predicts both the onset-driven heterosyllabic regressive [+VOICE] assimilation and the “progressive” tautosyllabic [-VOICE] assimilation.

(47) *First two syllables of Czech [přez.řa.dou.]: Regressive and Absolute Assimilation*

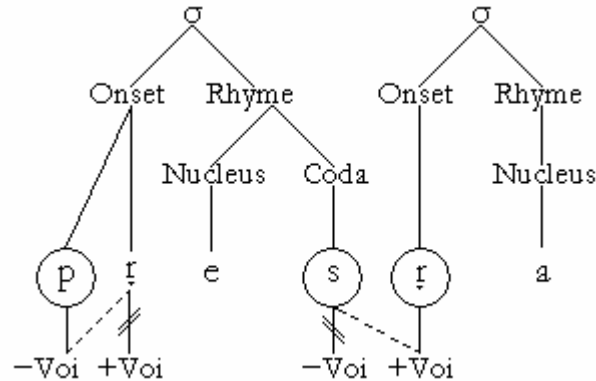

#### 4. Predictions of Selective Faithfulness Theory and (No) Majority Rules

##### 4.1 The Voicing Assimilation and Neutralization Typology

- (48) Selective Faithfulness also makes predictions about heterosyllabic clusters
- (49) *The typology predicted by Selective Faithfulness Theory has 11 cells*  
 (Dark grey shading indicates that type of language is not predicted; unshaded boxes are the predicted languages, and include examples of languages which exhibit that pattern.)

(50) The Voicing Typology

Assimilation Pattern	Neutralization Pattern		
	Complete	Coda	None
Regressive [+VOICE]			Ukrainian
Regressive [-VOICE]		Ya:thê' (?)	Ya:thê, Mekkan Arabic, Yorkshire English
Regressive [+/-VOICE]		Polish, Dutch, Czech, Slovak	Yiddish
Progressive [+VOICE]			
Progressive [-VOICE]			
Progressive [+/-VOICE]			
Bi-directional [+VOICE]			Swedish* (?)
Bi-directional [-VOICE]		Swedish' (?)	Swedish
Bi-directional [+/-VOICE]			
None	Hawaiian	German	Berber

(51) All attested patterns are accounted for (Polish, Yiddish, Ukrainian, Ya:thê, Swedish, German, Faithful, and Unmarked)<sup>8</sup>

(52) Predicts three unattested languages: Ya:thê' (with devoicing), Swedish' (with devoicing), and Swedish\* (bidirectional [+VOICE])

- NB: Clusters will pattern with their head for purposes of assimilation

#### 4.2 (No) Majority Rules

(53) ‘Majority Rules’ defines a situation where the output takes on the feature value that is most numerous in the input (e.g. Lombardi 1999, Baković 1999, de Lacy 2006, etc).

(54) *The Majority Rules Effect: the better represented value wins!*

/apzta/	→	[apsta]	/absda/	→	[abzda]
/apsda/	→	[apsta]	/abzta/	→	[abzda]

(55) *No Majority, no Majority Rules*

Only ever faithful to two adjacent specifications

(56) *Swedish data* (Lombardi 1999:285).

(a) /sku:g/	→	[sku:g]	‘forest’
(b) /vigsəl/	→	[viksəl]	‘marriage’
(c) /stekde/	→	[stekte]	‘fried’
(d) /ägde/	→	[ägde]	‘to own (preterite)’
(e) /skug+s+brand/	→	[skuk:spran:d]	‘forest (genitive) fire’

(57) *Danger: Environment for Majority Rules*

<sup>8</sup> Language examples are to represent an instantiation of a pattern, and is not the list of *languages* accounted for

/skug/+/s/+/brand/ → [skug:zbran:d] ‘forest fire’

- (58) *Selective Faithfulness Theory predicts the correct output:*  
 Since there is only faithfulness to heads, there will only be two competing voicing specifications—that of the onset-head, and that of the coda-head

- (59) *Background Ranking Information for Swedish*

	*SPEC[V]	IH−	IHO−	IH+	*LINK[+V]	IHO+
1. /sku:g/ → [.sku:g.] ~ [.sku:k.]	e <sub>2~2</sub>	e <sub>0~0</sub>	e <sub>0~0</sub>	<b>W</b> <sub>0~1</sub>	<b>L</b> <sub>1~0</sub>	e <sub>0~0</sub>
2. /stekde/ → [.stek.te.] ~ [.steg.de.]	e <sub>2~2</sub>	<b>W</b>	e <sub>0~0</sub>	<b>L</b> <sub>1~0</sub>	<b>W</b> <sub>0~2</sub>	<b>L</b> <sub>1~0</sub>
3. /vigsæl/ → [.vik.sæl.] ~ [.vig.sæl.]	<b>W</b> <sub>3~4</sub>	e <sub>0~0</sub>	e <sub>0~0</sub>	<b>L</b> <sub>1~0</sub>	<b>W</b> <sub>2~3</sub>	e <sub>0~0</sub>

(Row 1 shows that there is no final devoicing; row 2 shows the dominance of [−VOICE], as does Row 3.)

- (60) *No Majority Rules!*

/skug/+/s/+/brand/	*SPEC[V]	IH−	IHO−	IH+	*LINK[+V]	IHO+
1.  [skuk:spran:d.]	3			1	1	
2. ~[skug:zbran:d.]	e <sub>3~3</sub>	<b>W</b> <sub>0~1</sub>	<b>W</b> <sub>0~1</sub>	<b>L</b> <sub>1~0</sub>	<b>W</b> <sub>1~3</sub>	e <sub>0~0</sub>
3. ~[skug:sbran:d.]	<b>W</b> <sub>3~5</sub>	e <sub>0~0</sub>	e <sub>0~0</sub>	<b>L</b> <sub>1~0</sub>	<b>W</b> <sub>1~2</sub>	e <sub>0~0</sub>

(Row 1 is the actual output, and is predicted by Selective Faithfulness; row 2 is the Majority rules candidate, who loses due to faithfulness to [−VOICE]; Row 3 shows the faithful candidate, doomed by \*SPEC[V] .)

- (61) L99 can not correctly predict the Swedish data; the constraint system produces a majority rules effect, due to the IDENT constraint which makes reference to both feature values and the mistaken definition of head. [See Appendix Two for a proof]

## 5. Conclusions

- (62) *Heads are necessary*  
 It is necessary to define a head for each syllable constituent
- (63) *Onset-head-driven assimilation*  
 “Progressive tautosyllabic”, “regressive tautosyllabic” and “regressive heterosyllabic” assimilation can be seen as driven by faithfulness to the onset head.
- (64) *Predictions of Selective Faithfulness Theory*
- Predicts *no* voicing disagreement in monomorphemic tautosyllabic obstruent-obstruent clusters (*Absolute Assimilation*)
  - Predicts voicing disagreement in obstruent-sonorant clusters as the result of markedness constraints, *not faithfulness*
  - Accounts for all known voicing assimilation and neutralization patterns
  - Avoids the Majority Rules problem

APPENDIX ONE: THE SPLIT FAITHFULNESS HYPOTHESIS

(65) *Independent Assimilation*

There are languages which *independently* regressively spread either [-VOICE] (Ya:thê, Mekkan Arabic) or [+VOICE] (Ukrainian)

(66) *Account: Faithfulness to each feature value*

Splitting up [VOICE] faithfulness into two constraints, each of which favor one of the values of the [VOICE] feature. (Stringent faithfulness can't do the job!)

(67) *Ukrainian data* (Butska 1998 and de Lacy 2003)

(a) /jak/+/ze/ → [ja**g**-ze] ‘as with’ cf. [jak-ɪj] ‘which, what’

(b) /liʒ/+/ko/ → [liʒko] ‘bed-nom.neuter’, \*[liʒ-ok] ‘bed-gen.pl’

(68) *Ukrainian Regressive [+VOICE] Assimilation*

/jak/+/ze/	IHO-	IH+	IHO+	*SPEC[V]	*LINK[+V]	IH-
a.  [ja <b>g</b> .ze.]				2	2	1
b. ~[.ja <b>k</b> .se.]	e <sub>0~0</sub>	<b>W</b> <sub>0~1</sub>	<b>W</b> <sub>0~1</sub>	e <sub>2~2</sub>	<b>L</b> <sub>2~0</sub>	<b>L</b> <sub>1~0</sub>
c. ~[.ja <b>k</b> .ze.]	e <sub>0~0</sub>	e <sub>0~0</sub>	e <sub>0~0</sub>	<b>W</b> <sub>2~3</sub>	<b>L</b> <sub>2~1</sub>	<b>L</b> <sub>1~0</sub>

(Faithfulness to the [+VOICE] onset head prevents progressive assimilation)

(69) *No Ukrainian Regressive [-VOICE] Assimilation*

/liʒ/+/ko/	IHO-	IH+	IHO+	*SPEC[V]	*LINK[+V]	IH-
d.  [liʒ <b>.</b> ko.]				3	1	
e. ~[.liʒ <b>.</b> ko.]	e <sub>0~0</sub>	<b>W</b> <sub>0~1</sub>	e <sub>0~0</sub>	<b>L</b> <sub>3~2</sub>	<b>L</b> <sub>1~0</sub>	e <sub>0~0</sub>
f. ~[.liʒ <b>.</b> go.]	<b>W</b> <sub>0~1</sub>	e <sub>0~0</sub>	e <sub>0~0</sub>	<b>L</b> <sub>3~2</sub>	<b>W</b> <sub>1~2</sub>	<b>W</b> <sub>0~1</sub>
g. (48)3. <sup>o</sup> (50)3. <sup>o</sup>	<b>W</b>	<b>W</b>	e	<b>L</b>	<b>L</b>	<b>L</b>

(Faithfulness to the [+VOICE] coda head prevents regressive assimilation and faithfulness to the [-VOICE] onset head prevents progressive assimilation)

(70) *Ranking for Ukrainian:*

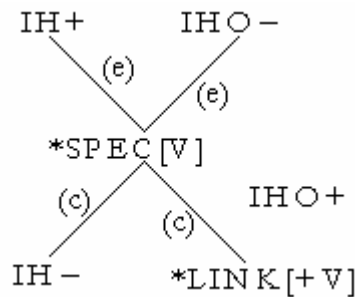

<sup>9</sup> This operation is *fusion*, as in relevance logic. Two ERCS – two lines in a comparative tableau – “fuse” to form a new ERC which handles both (or all) competitions simultaneously (Prince 2002).

- (71) *Ya:thé Data* (Wetzels and Mascaró 2001).
- Regressive [-VOICE] Assimilation
    - (a) /fowa/+/desa/ → [.fo.wat.sa.] ‘of the stone’
    - (b) /i/+/e/+/da/+/ka/ → [.i.et.k<sup>h</sup>a.] ‘I let him’
  - No Regressive [+VOICE] Assimilation
    - (c) /i/+/kfake/+/dode/+/ka/ → [.ik.fak.dot.k<sup>h</sup>a.] ‘I cannot’
    - (d) /i/+/t<sup>h</sup>ate/+/de/ → [.i.t<sup>h</sup>at.de.] ‘from my mouth’
  - No Coda Voicing Neutralization
    - (e) /a/+/ek<sup>h</sup>de/+/dode/+/ma/ → [.æk<sup>h</sup>dod.ma.] ‘when you do not know’

(72) *Ya:thé Regressive [-VOICE] Assimilation*

/i/+/e/+/da/+/ka/	*SPEC[V]	IHO-	IHO+	IH+	*LINK[+V]	IH-
1.  [.i.et.k <sup>h</sup> a.]	1			1		
2. ~ [.i.ed.k <sup>h</sup> a.]	<b>W</b> <sub>1~2</sub>	e <sub>0~0</sub>	e <sub>0~0</sub>	<b>L</b> <sub>1~0</sub>	<b>W</b> <sub>0~1</sub>	e <sub>0~0</sub>
3. ~ [.i.ed.g <sup>h</sup> a.]	e <sub>1~1</sub>	<b>W</b> <sub>0~1</sub>	e <sub>0~0</sub>	<b>L</b> <sub>1~0</sub>	<b>W</b> <sub>0~1</sub>	<b>W</b> <sub>0~1</sub>

(Faithfulness to the [-VOICE] onset head prevents progressive assimilation)

(73) *No Ya:thé Regressive [+VOICE] Assimilation*

/i/+/t <sup>h</sup> ate/+/de/	*SPEC[V]	IHO-	IHO+	IH+	*LINK[+V]	IH-
1.  [.i.t <sup>h</sup> at.de.]	2				1	
2. ~ [.i.t <sup>h</sup> at.te.]	<b>L</b> <sub>2~1</sub>	e <sub>0~0</sub>	<b>W</b> <sub>0~1</sub>	<b>W</b> <sub>0~1</sub>	<b>L</b> <sub>1~0</sub>	e <sub>0~0</sub>
3. ~ [.i.t <sup>h</sup> ad.de.]	<b>L</b> <sub>2~1</sub>	e <sub>0~0</sub>	e <sub>0~0</sub>	e <sub>0~0</sub>	<b>W</b> <sub>1~2</sub>	<b>W</b> <sub>0~1</sub>
4. (55)2°(56)2.	<b>L</b>	e	<b>W</b>	<b>L</b>	<b>L</b>	E

(Faithfulness to the [-VOICE] coda head prevents regressive assimilation and faithfulness to the [+VOICE] onset head prevents progressive assimilation)

(74) *No Coda Devoicing (simplified)*

/dode/+/ma/	*SPEC[V]	IHO-	IHO+	IH+	*LINK[+V]	IH-
1.  [.dod.ma.]	3				3	
2. [.dot.ma.]	e <sub>3~3</sub>	e <sub>0~0</sub>	e <sub>0~0</sub>	<b>W</b> <sub>0~1</sub>	<b>L</b> <sub>3~2</sub>	e <sub>0~0</sub>
3. (55)2°(57)2.	<b>W</b>	e	e	<b>L</b>	<b>L</b>	E
4. (55)3°(57)3.	<b>L</b>	e	e	<b>L</b>	<b>L</b>	<b>W</b>

(Faithfulness to the [+VOICE] coda head prevents devoicing. Line 2 of this tableau fused with line 2 of (55) shows the dominance of \*SPEC[V]; line 3 of this tableau fused with line 3 in (57) shows the dominance of IH- )

(75) *Ranking for Ya:thé*

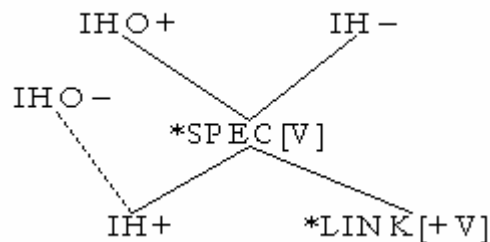

APPENDIX TWO: LOMBARDI 1999 AND MAJORITY RULES

(76) *Constraint Set from L99:*

IDENTONSET(LARYNGEAL) (=: IDONSLAR)

Consonants in the position stated in the Laryngeal Constraint (1) should be faithful to underlying laryngeal specification.

IDENT(LARYNGEAL) (=: IDLAR)

Consonants should be faithful to underlying laryngeal specification.

\*LAR<sup>10</sup>

Do not have laryngeal features

AGREE **W**

Obstruent Clusters should agree in voicing

(77) The ranking of these constraints needed to derive the Swedish data in (48 a–d) is:

AGREE >> IDLAR >> \*LAR >> IDONSLAR

as is shown in the tableau

(78) *Swedish Ranking Data*

	AGREE	IDLAR	*LAR	IDONSLAR
1. /sku:g/ → [sku:g] ~ [sku:k]	e <sub>0~0</sub>	<b>W</b> <sub>0~1</sub>	<b>L</b> <sub>1~0</sub>	e <sub>0~0</sub>
2. /stekde/ → [stekte] ~ [stegde]	e <sub>0~0</sub>	e <sub>1~1</sub>	<b>W</b> <sub>0~2</sub>	<b>L</b> <sub>0~1</sub>
3. /vigsəl/ → [viksəl] ~ [vigsəl]	<b>W</b> <sub>0~1</sub>	<b>L</b> <sub>1~0</sub>	<b>W</b> <sub>1~2</sub>	e <sub>0~0</sub>
4. 1°3	<b>W</b>	<b>L</b>	<b>L</b>	<b>L</b>

• The Tableau in (61) gives the arguments for the ranking in (54): IDLAR dominates \*LAR, as shown in line 1, to prevent coda devoicing; \*LAR dominates IDONSLAR, as shown in line 2, to achieve progressive devoicing, and AGREE dominates IDLAR, as shown in line 4, given the fusion of lines 1 and 3, to predict regressive devoicing.

(79) *Majority Rules!*

This ranking, however, does not predict the correct output for /sku:g+s+brand/ ([skuk:spran:d]); instead, it predicts the Majority Rules candidate [skug:zbran:d]

(80) /skug+s+brand/ → **☛** [skug:zbran:d] ‘forest fire’ (Swedish)

/sku:g+s+brand/	AGREE	IDLAR	*LAR	IDONSLAR	Remarks
1. [skuk:spran:d.]	0	2	0	1	actual output
2. <b>☛</b> ~ [skug:zbran:d.]	e <sub>0~0</sub>	L <sub>2~1</sub>	W <sub>0~3</sub>	L <sub>1~0</sub>	predicted!!
3. ~ [skug:sbran:d.]	W <sub>0~2</sub>	L <sub>2~0</sub>	W <sub>0~2</sub>	L <sub>1~0</sub>	faithful

<sup>10</sup> Violations are counted segmentally.

## REFERENCES

- Bakovic, Eric. 1999. Assimilation to the Unmarked. University of Pennsylvania. Working Papers in Linguistics 6.1, 1-16. [ROA-340.]
- Bakovic, Eric. to appear. Local assimilation and constraint interaction. In *The Cambridge Handbook of Phonology*, Paul de Lacy (ed.). Cambridge University Press.
- Beckman, Jill. 1998. Positional Faithfulness. Ph. D. Dissertation, University of Massachusetts at Amherst. ROA-234, <http://ruccs.rutgers.edu/roa.html>.
- Butska, Luba. 1998. Faithfulness and Voicing Alternations in Ukrainian, Ms, Rutgers University.
- de Lacy, Paul. 2002. The Formal Expression of Markedness. Doctoral Dissertation. University of Massachusetts, Amherst. Rutgers Optimality Archive #542
- de Lacy, Paul. 2006. *Markedness: Reduction and Preservation*. Cambridge Studies in Linguistics. Cambridge University Press.
- Greenberg, Joseph H. 1978. Some generalizations concerning initial and final consonant clusters. In *Universals of human language*, Vol. 2: Phonology, ed. Joseph H. Greenberg. Stanford, CA: Stanford University Press.
- Hall, Daniel Currie. 2003. Laryngeal Feature Specifications in West Slavic Languages. *Toronto Working Papers in Linguistics*, 20: 93 – 114.
- Katz, Dovid. 1987. *Grammar of the Yiddish Language*. Duckworth, London.
- Kehrein, Wolfgang and Chris Golston. 2004. A Prosodic Theory of Laryngeal Contrasts. In *Phonology* 21: 325-57.
- Ketner, Katherine. 2005 “The phonology of Czech [ř].” University of Cambridge, Ms.
- Kučera, Henry. 1961. *The Phonology of Czech*. The Hague, Netherlands: Mouton & Co.
- Lombardi, Linda. 1999. Positional faithfulness and Voicing Assimilation in Optimality Theory. NLLT.
- McCarthy, John & Alan Prince. 1994. The Emergence of the Unmarked. ROA-13. 47pp. In Mercè González, ed., NELS 24: Proceedings of [the 1993 meeting of] the Northeastern Linguistic Society, Vol. 2, 333-379. GLSA: Amherst, MA.
- McCarthy, John & Alan Prince. 1993. Prosodic Morphology: Constraint Interaction and Satisfaction. RuCCS-TR-3. ROA-482.
- Morelli, Frida. 1999. *The Phonotactics and Phonology of Obstruent Clusters in Optimality Theory*. Doctoral Dissertation; University of Maryland.
- Palková, Zdena. 1994. *Fonetika a fonologie češtiny s obecným úvodem do problematiky oboru*. Prague: Univerzita Karlova.
- Prince, Alan, and Paul Smolensky. 1993/2002. Optimality Theory: Constraint Interaction in Generative Grammar. Rutgers University Center for Cognitive Science Technical Report 2. [revised 2002. ROA Version; <http://roa.rutgers.edu/files/537-0802/537-0802-PRINCE-0-0.PDF>]
- Prince, Alan. 2002. Entailed Ranking Arguments. <http://roa.rutgers.edu/files/500-0202/500-0202-PRINCE-0-1.PDF>
- Wetzels, W. Leo and Joan Mascaró. 2001. The Typology of Voicing And Devoicing. *Language* 77(2). 207-244

Sarah E. Murray  
 Department of Linguistics  
 Rutgers, The State University of New Jersey  
 18 Seminary Place  
 New Brunswick, NJ 08901  
[semurray@rutgers.edu](mailto:semurray@rutgers.edu)