

THOMAS A. EDISON.

Improvement in Printing-Telegraphs.

No. 126,534.

Patented May 7, 1872.

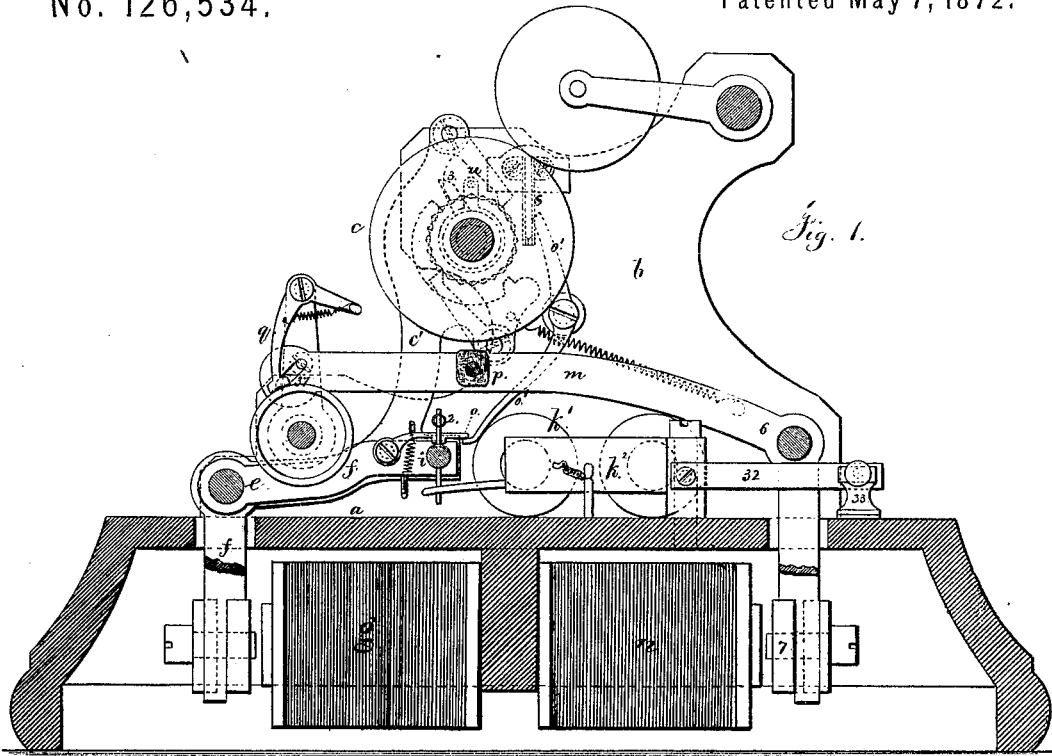

Fig. 1.

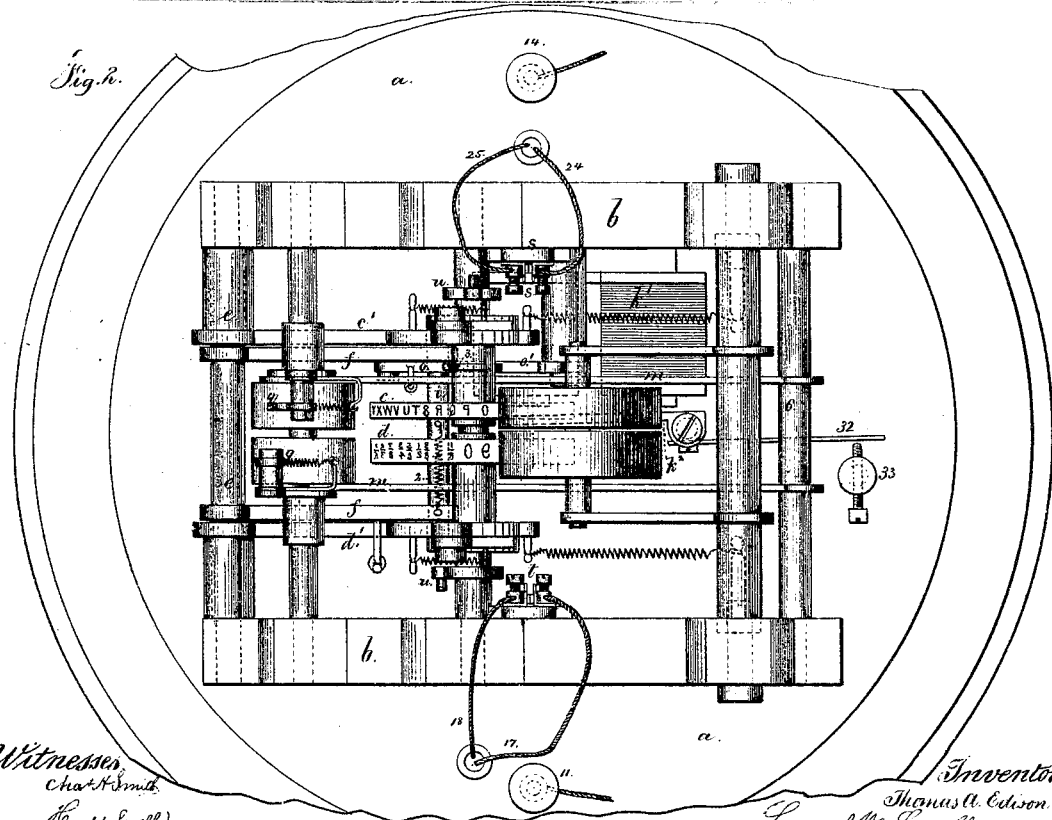

Fig. 2.

Witnesses
 Cha^s Smith
 Rowd Small

Inventor
 Thomas A. Edison
 Lemuel W. Percell atty

THOMAS A. EDISON.

Improvement in Printing-Telegraphs.

No. 126,534.

Patented May 7, 1872.

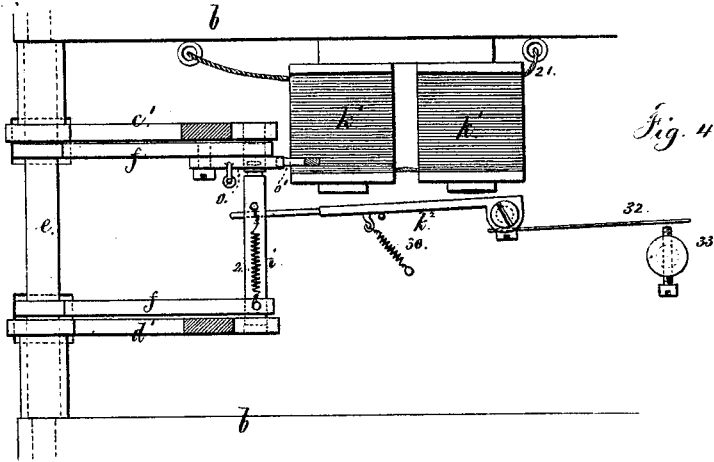
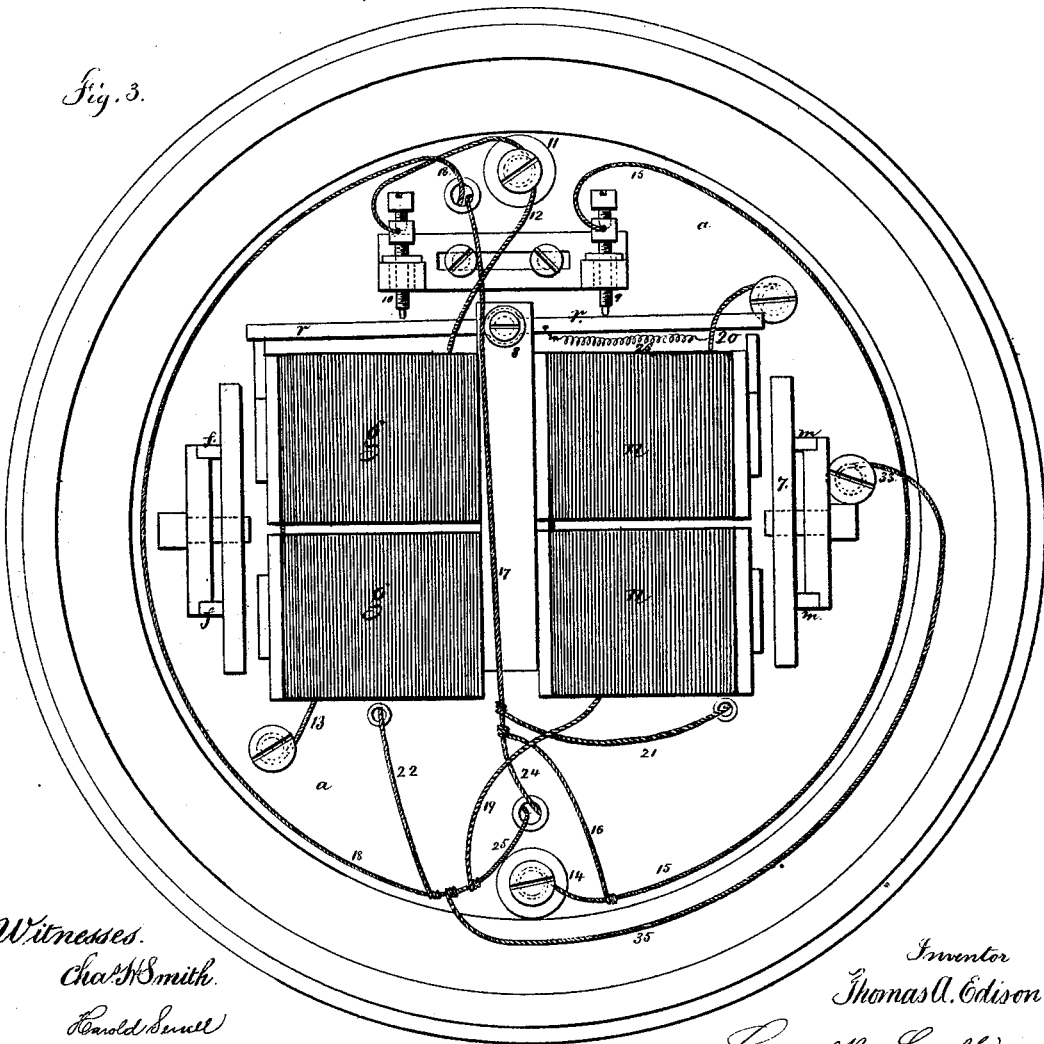

Fig. 4.

Fig. 3.



Witnesses.
 Cha^s Smith.
 Harold Sewell

Inventor
 Thomas A. Edison
 Lemuel M. Sewell atty

UNITED STATES PATENT OFFICE.

THOMAS A. EDISON, OF NEWARK, NEW JERSEY, ASSIGNOR TO GOLD AND STOCK TELEGRAPH COMPANY, OF NEW YORK CITY.

IMPROVEMENT IN PRINTING-TELEGRAPHS.

Specification forming part of Letters Patent No. 126,534, dated May 7, 1872.

To all whom it may concern:

Be it known that I, THOMAS A. EDISON, of Newark, in the county of Essex and State of New Jersey, have invented an Improvement in Printing-Telegraphs; and the following is declared to be a correct description of the same.

This telegraph is made for printing from one of two type-wheels. The type-wheels are contiguous, and revolved by separate ratchets and pawls, or step-by-step motions, and a magnet is employed to operate a bolt that connects one of the step-by-step movements with the lever and armature of an electro-magnet, and a latch holds the parts thus connected. This latch is lifted every rotation of the locked letter type-wheel, hence is unlocked, and a spring causes the bolt to connect the armature-lever to the step-by-step motion of the number or character wheel, hence that will be rotated; but should it be desired to continue the rotation of the letter-wheel, a pulsation of opposite polarity operates in the impression-magnet, and through a connection to the locking-magnet, and relocks the letter-wheel and disconnects the figure-wheel. At all times, except when the letter and figure wheels are at the zero or nonus points, the locking-magnet is prevented from acting when an impression is made by a circuit-closer that gives a shorter and more direct route for the electricity, and hence cuts out the locking-magnet. This circuit-closer is opened by a non-conducting arm revolving with the type-wheel at the zero point.

In the drawing, Figure 1 is a vertical section of the instrument. Fig. 2 is a general plan. Fig. 3 is an inverted plan; and Fig. 4 is a plan of the locking-magnet, bolt, and levers.

Upon the bed *a* are the frames *b b*, sustaining a shaft that carries the type-wheels *c* and *d*, the type-wheel *c* having letters, and the wheel *d* figures and fractions, or other characters adapted to the use for which the instrument is intended. The lever *e* is provided with the necessary pawls and stops to act upon the ratchet of the letter-wheel *c*, and move the same with a step-by-step motion, and *d'* is the lever, with similar devices to form a step-by-step motion for the figure-wheel *d*. These step-by-step motions, being of ordinary character, do not require further description. The levers *e d'* move upon a fulcrum or shaft, *e*,

which is also the axis for the lever *f*, and armature of the electro-magnet *g*, designated herein in the type-wheel magnet. The bolt *i* slides in the lever *f*, and when moved toward the lever *d'* by the spring 2, that end of the bolt *i* connects the lever *d'* with *f*, and they move together, and the lever *e* is disconnected. When the bolt *i* is moved the other way the lever *d'* is disconnected from *f* and the lever *e* connected by the other end of *i*, and in order to hold the bolt *i* a latch, *o*, is employed that springs into a notch in *i*. A lever, *o'*, beneath the end of the latch *o*, extends upward contiguous to a cam, 3, moving with the type-wheel *c*, so that at each revolution of *c* the latch *o* is lifted and the bolt *i* drawn from *e* by the spring 2. The bolt *i* is moved toward *e* by the armature *k* of the locking-magnet *k'*. The printing-lever *m* moves upon the fulcrum 6, and carries the armature 7 of the printing-magnet *n*. The impression-pad *p*, feeding-clamps *q*, and actuating cam-slots 37 are of any usual character. The polarized circuit-changer *r*, swinging upon the fulcrum 8, and moved into contact with the circuit screw-connections 9 and 10, according to the polarity of the current, is substantially similar to devices shown in patents heretofore granted to me, in which the current is directed either through the printing-magnet or else through the type-wheel magnet, according to its polarity. The spring circuit-closers *s* and *t* are near the type-wheel shaft, and upon the sleeves or shafts of the respective type-wheels there are arms *u*, with non-conducting pins projecting from the sides, and passing in their revolution between the ends of the circuit-closing springs *s* or *t*, respectively, and opening them break the circuit, and these pins and arms are located so as to separate these springs *s t* when the type-wheels arrive at the zero points. The line-wires connect with the binding-screws 11 and 14.

The operation of this instrument is illustrated as follows: Suppose letter-wheel *c* at zero point and the circuit-springs *s* separated, and the bolt *i* connecting *f* and *d'*, the pulsation of electricity entering by 10 goes by wire 12 to magnet *g*; thence, by wire 13, to bed *a*, and by 8 and *r* through 9, wire 15, and to the line-screw 14. The pulsations, therefore, will act in the magnet *g* upon the step-by-step mo-

tion to set the wheel *d*. When the polarity of the current is reversed to effect the printing, the same enters at 14, passes through wires 16 and 17, springs *t*, wires 18 and 19, to the printing-magnet *n*; thence, by 20, to bed *a*, and by 8, *r*, and 10 to the line-wire from 11. To operate the letter-wheel *c* it is necessary to move the wheel *d* to the zero point, breaking the circuit at *t*; then reverse the pulsation, which then cannot go by 16, 17, 18, 19, &c., as before, because *t* is open; but it has to pass through 21 to the locking-magnet *k'*, which throws the bolt *i*, unlocking *d'* and locking *c'*. The pulsation then goes, by 22, 19, through *n*, 20, *a*, 8, *r*, 10, and 11. The latch *o* holds the bolt *i*, and upon reversing the polarity of the current the letter-wheel can be moved around by the step-by-step motion and the printing done as before; but the pulsations in the type-wheel magnet pass from 11 through 12, *g*, 13, *a*, 8, *r*, thence by 9 and 15 to 14. When the impression is made on the letter-wheel *c* the pulsation comes through 14, 16, 24, 25, 19, *n*, 20, *a*, 8, *r*, 10, to 11, and if the letter-wheel *c* is to be revolved more than once, a reverse pulsation must be made upon the arrival of *c* at the zero point, because the cam 3 has in its last step unlatched *o* and allowed the spring 2 to draw the bolt *i* back from *c'*. This pulsation, as it cannot go through either *s* or *t*, has to go through the magnet *k¹*, and, by the armature *k²*, move and relock the bolt *i* to *c'*. In order to prevent the armature *k²* remaining in contact with *k¹* by any residual magnetism, I make the movement of the armature close the circuit between 32 and the insulated screw 33, so that there is a connection made from 22 through 35, 33, 32, to the bed *a*. The circuit at 32 33 is again broken as the armature is drawn back by the spring 30. A fine wire, 36, between *r* and 20, prevents the circuits being broken if the polarized switch

r should not touch either 9 or 10. The locking-magnet *k¹* might be operated by a separate line-wire; and either of the circuit-springs *s* or *t* may be employed with the pin on the type-wheel shaft for cutting out an electro-magnet, or compelling the circuit to pass through the same when the non-conducting pin intervenes between the springs.

I claim as my invention—

1. Two type-wheels, actuated by separate levers and step-by-step movements, in combination with an actuating electro-magnet, armature, and bolt that locks either of the levers with the actuating-armature, substantially as set forth.

2. An electro-magnet for operating the locking-bolt, in combination with the said levers, step-by-step movements, and type-wheels, substantially as set forth.

3. The latch *o* for holding the bolt *i* unlatched by the cam 3 upon the type-wheel shaft, in combination with the armature and levers to actuate the type-wheels, substantially as set forth.

4. The circuit-closing springs *s* or *t*, separated by the non-conducting pin upon the type-wheel shaft, in combination with an electro-magnet for directing the pulsation through that magnet when the pin is between the springs, substantially as specified.

5. The arrangement of circuit-connections, substantially as set forth, for actuating either of three electro-magnets in one main telegraph line, for moving one of two type-wheels and effecting the printing, substantially as set forth.

Signed by me this 17th day of January, A. D. 1872.

T. A. EDISON.

Witnesses:

GEO. D. WALKER,
GEO. T. PINCKNEY.