

(No Model.)

T. A. EDISON.
Electric Light.

No. 237,732.

Patented Feb. 15, 1881.

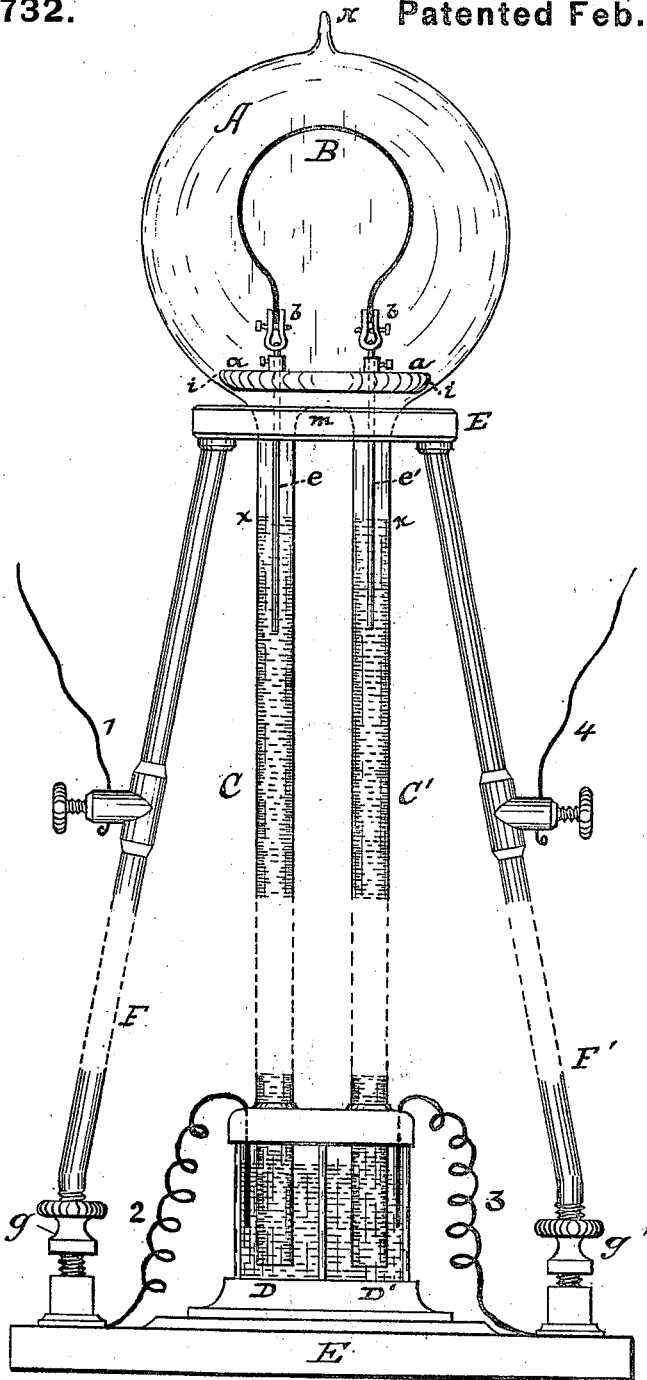

Attest=

D. D. Mott
James A. Payne.

Inventor=

Thos. A. Edison
per Dyer & Wilber
Attys.

UNITED STATES PATENT OFFICE.

THOMAS A. EDISON, OF MENLO PARK, NEW JERSEY.

ELECTRIC LIGHT.

SPECIFICATION forming part of Letters Patent No. 237,732, dated February 15, 1881.

Application filed June 30, 1880. (No model.)

To all whom it may concern:

Be it known that I, THOMAS A. EDISON, of Menlo Park, in the county of Middlesex and State of New Jersey, have invented a new and useful Electric Light, (Case No. 220;) and I do hereby declare that the following is a full and exact description of the same, reference being had to the accompanying drawings, and to the letters of reference marked thereon.

In several prior applications made by me, and in several patents granted me for improvements in electric lights, the light is produced by the incandescence of a conductor in a hermetically-sealed vessel, the incandescing conductor being the small carbon now generally designated as the "horseshoe carbon." Such, however, are designed for small lamps, usually fifteen to eighteen candle-power, and the conductor required therefrom, being small, is hermetically sealed in glass. When it is desired to produce on the same principle a much greater light—say, one hundred candle-power—the conductor thereto must be also much larger. While I have succeeded in satisfactorily sealing somewhat larger conductors hermetically in the glass, it is generally not so effective or desirable a method of passing large conductors into the bulb as where small conductors are used, wherefore there seems to be a necessity for some other method, which, in the case of large conductors, shall pass the conductors into the bulb of the lamp without contact with the glass thereof, and at the same time furnish an effective and lasting hermetical seal.

To furnish such a method is the object of this invention, which consists, in general terms, in the employment in the lamp of two columns of mercury, sustained in tubes attached to the lamp-bulb at ordinary barometric height by the pressure of the atmosphere, and serving both as seals to preserve the vacuum in the lamp-bulb and as parts of the circuit through the incandescing conductor; and the invention consists, further, in the devices and combinations for carrying the same into effect, as more particularly hereinafter described and claimed.

In the drawing, the figure is a view of a lamp embodying the invention, shortened somewhat in proportion to its height, as indicated in the dotted lines.

A glass globe or bulb, A, is blown, having

an annular opening in its base of a size to admit of the base *a a* passing therethrough. The line of this opening is indicated at *i i*.

Upon the top of the bulb is formed a tube, (the continuation of the projection N,) by which the lamp is attached to the air-pump, as described in a prior application.

Upon a suitable base, *a a*, of insulating material, are fastened, by proper devices, the clamps *b b*, holding and supporting the horseshoe B, the clamps being connected to metallic conductors *e e'*, passing a little distance, say, several inches, below the base *a a*.

Two glass tubes, C C', each of a diameter several times greater than that of *e* or *e'*, and several inches longer than a column of mercury supported *in vacuo* by atmospheric pressure, are united, near their top, as at *m*, and their united tops formed into a circle the diameter of or slightly larger than the diameter *i i* of the opening in A. The base *a a* supporting the carbon, and with its attached conductors, is introduced into A, and the tubes C C' are then secured, by sealing at *i i* to A, the conductor *e* projecting downwardly into C, and *e'* into C'. For supporting the lamp thus formed, a stand is employed consisting of an insulating-top, B, and base E', united by metallic standards F F', which are connected to the base E' by adjustable screw-connections *g g'*, so that, as circumstances require, the top may be raised, lowered, or inclined. Upon the metal standards F F' are binding-screws, whereby conductors 1 4 to and from the source of electric energy are attached. The top E is provided with a central aperture, or it may be annular, permitting the tubes C C' to pass through and below it, while supporting the globe.

Upon the base E is located a vessel made of insulating material not affected by mercury, divided into compartments D D'; or two separate distinct vessels may be used. The tube C passes into one, D, to near its bottom, while C' passes into D'. A wire, 2, connects D and E, and a wire, 3, connects D' and E'.

The parts being placed in position as shown in the figure, the vessels D D' are filled with mercury, and the tube-continuation of N, before mentioned, fastened to the pumps. As the air is exhausted from the bulb the mer-

cury rises in C and C'. During this operation care must be taken that the compartments D D' are kept supplied with mercury, and that upon the completion they are still full. Upon the proper degree of vacuum being attained the bulb is sealed at N and the tube removed. At this stage the mercury has risen to and remains at x —the height at which atmospheric pressure sustains a column of mercury *in vacuo*—the mercury contacting with $e e'$ and passing a little distance above their ends.

The columns C C' should be of such a diameter as to give no greater resistance to the circuit than does either of the conductors $e e'$, 2, 15 or 3.

For high candle-power incandescent lamp this arrangement makes a very reliable and durable seal, obviating any danger there may be of seal-breakage arising from difference of expansion coefficient likely to exist where a large metallic conductor is sealed directly to or in glass. For such reason, in large lamps, this method may prove preferable to that of sealing direct, as shown in some of my prior 20 applications. 25

What I claim is—

1. The combination, with the incandescing conductor of an electric lamp, of two fluid columns sustained by atmospheric pressure and forming both a part of the circuit and the hermetical seal to the lamp, substantially as set forth. 30

2. The combination, with the incandescing conductor and the fluid columns, of reservoirs connected to the source of electricity, and into which the columns dip for the maintenance of the column and the completion of the circuit therethrough, substantially as set forth. 35

3. The combination, with an electric lamp, of the stand or support therefor, consisting of an insulating base and top connected by adjustable standards, substantially as set forth. 40

This specification signed and witnessed this 15th day of June, 1880.

THOMAS A. EDISON.

Witnesses:

S. L. GRIFFIN,
WM. CARMAN.