

(No Model.)

2 Sheets—Sheet 1.

T. A. EDISON.
MAGNETIC SEPARATOR.

No. 248,432.

Patented Oct. 18, 1881.

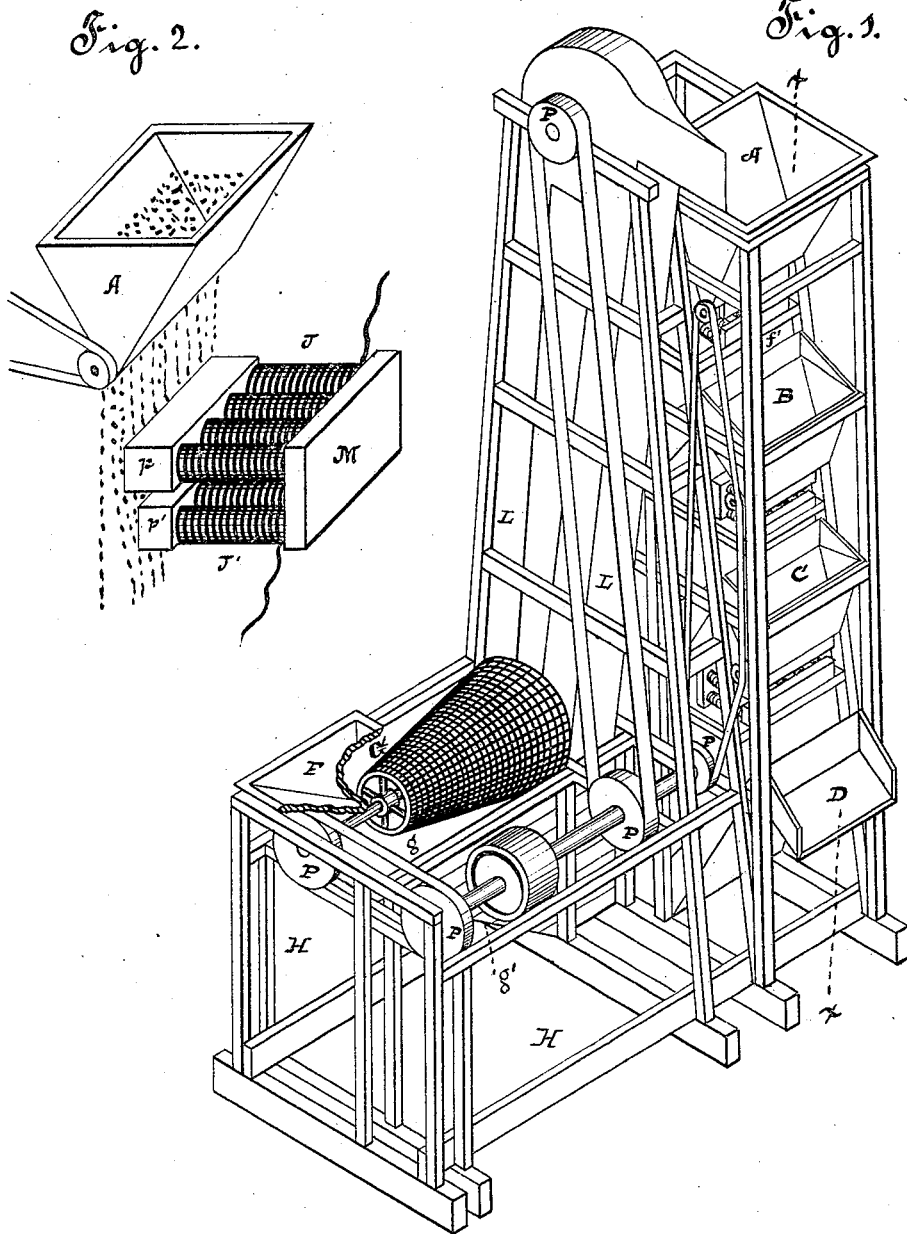

Attest:

D. D. Mott
P. H. Hall

Inventor:

Thos. A. Edison.
by
Dyer & Miller

Attys

(No Model.)

2 Sheets—Sheet 2.

T. A. EDISON.
MAGNETIC SEPARATOR.

No. 248,432.

Patented Oct. 18, 1881.

Fig. 3.

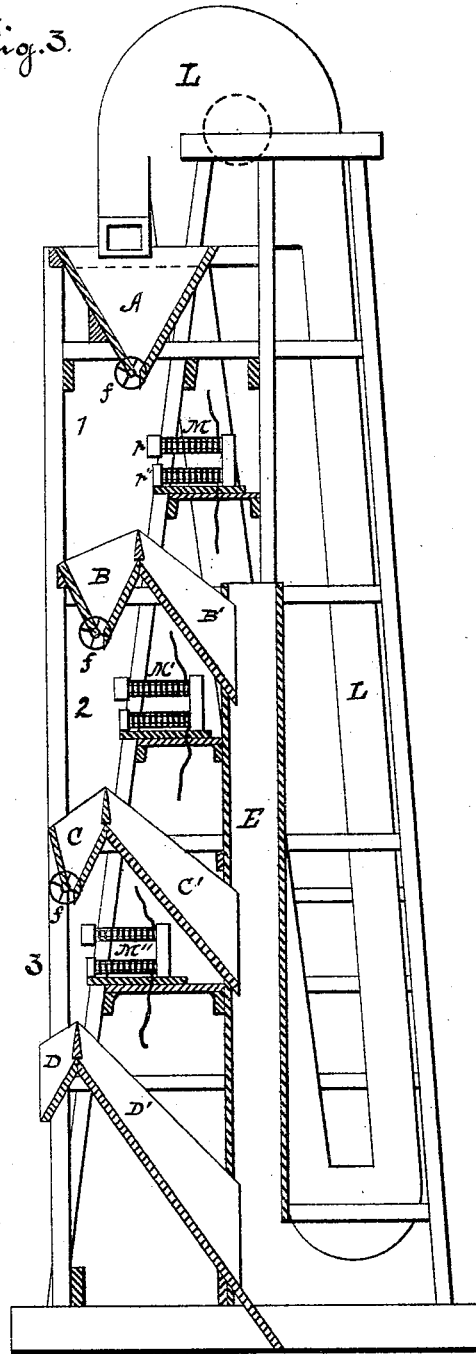

Attest:
 D. W. Mott
 P. H. Hall

Inventor:
 Thos. A. Edison
 by Dyer & Miller
 Attys

UNITED STATES PATENT OFFICE.

THOMAS A. EDISON, OF MENLO PARK, NEW JERSEY, ASSIGNOR TO EDISON ORE MILLING COMPANY, (LIMITED,) OF NEW YORK, N. Y.

MAGNETIC SEPARATOR.

SPECIFICATION forming part of Letters Patent No. 248,432, dated October 18, 1881.

Application filed August 6, 1880. (No model.)

To all whom it may concern:

Be it known that I, THOMAS A. EDISON, of Menlo Park, in the county of Middlesex and State of New Jersey, have invented a new and useful Improvement in Magnetic Separators; and I do hereby declare that the following is a full and exact description of the same, reference being had to the accompanying drawings, and to the letters of reference marked thereon.

In Letters Patent of the United States, No. 228,329, granted me June 1, 1880, is shown a device for separating magnetic and non-magnetic substances, consisting, essentially, of a magnet past whose poles fall the mingled substances, the attraction of the magnet acting to alter the path of the magnetic substance, drawing it out and away from the non-magnetic portion, the magnetic and non-magnetic substances falling into different receptacles.

The invention in this case relates to improvements upon the invention therein shown; and it consists in the features more particularly hereinafter specified and claimed.

In this invention U-shaped electro-magnets are used, made up of one or of several series of coils. Where several series of coils are used their polar faces or extensions are united to form one polar face or extension for one polarity, the polar faces being placed at right angles to the flow of the material to be treated. The magnetic material is acted on consequently by both poles. As the first draws it out of its path, if the second were in the same plane relatively to the flow of material, it would act on the material at a shorter distance than the first, and would possibly attract the material to itself. To avoid this it is better to place the active faces of the polar extensions in different planes relatively to the flow of material, the second being placed to the rear of the first, a distance approximately equal to the distance the first draws the magnetic material out of its path. From the fact that often a particle or particles of non-magnetic substance come between particles of the magnetic substances and the attractive force acting on them, such magnetic particles are not drawn out of their path sufficiently, and fall with the non-magnetic substances; hence it is preferable that the material be subjected to the action of the separator

several times in order to insure thorough separation. As some portion of the substance to be treated is more magnetic than another, this more magnetic portion is apt to be drawn out of its path and separated by the first separator. Moreover, if the magnets be too near the path of the very magnetic material, they would be apt to draw the material to themselves, which, clinging thereto, would soon clog the magnets, constantly extending their poles; hence the magnets of the first separator are placed at some distance from the path of the material. In order, then, to act equally on the less magnetic portion, it is preferable that the next set of magnets be placed somewhat nearer the path of the falling material, and so with each succeeding separator of the series. To accomplish this, several—preferably three—separators are arranged in series, somewhat in echelon, so that the portion which passes into the non-magnetic receptacle of the first passes immediately to the second separator, and so on through the series, the magnetic receptacles of all the series leading to a common delivery-chute. Combined with this series is a suitable hopper and sieve and elevator for carrying the sifted material up and delivering it to the first separator of the series.

In the drawings, Figure 1 represents a series of separators and accessories mounted in a suitable framing; Fig. 2, a single hopper and magnet in detail; and Fig. 3, a series of magnetic separators in section, taken on line $x x$ of Fig. 1.

H H H, &c., is any suitable framing, in which are secured the separators 1 2 3, each consisting, essentially, of a hopper and magnet, as A M, B M', and C M''.

The material to be treated is first fed into a hopper, F, whence it passes into a sieve, G, as all lumps, stones, &c., should be separated from the material to be treated. The sifted material falls into a receptacle, g , having an inclined bottom, g' , which feeds it into the bottom of an elevator, L, while the lumps, stones, &c., from G are delivered to a wasteway. (Not shown.) The elevator L conveys the material to the hopper A of the first separator, whence it falls in front of the magnet M. Below M is a hopper, B, receiving the less and the non-mag-

netic portion and passing it before the second magnet, M' , the magnetic portion falling into B' and thence into the delivery-chute E . Below M' is a similar hopper, C , passing the less and the non-magnetic material before M'' , and the passage C' passing the magnetic portion into the delivery-chute E . This construction and relation are repeated until as many separators as may be desired are arranged in the series.

It will be noticed that each succeeding magnet is set nearer the path of the material than its predecessor in the series. For instance, M'' is nearer such path than M' , and M' than M .

It will also be noticed that the active faces of the lower polar extension of each magnet are set back a short distance from that of the upper polar extension, this distance being approximately equal to the distance the latter draws the magnetic material out of its path.

Motion is communicated to the various portions of the series by means of belts and the pulleys $P P$, &c.

When desired, it is evident that the elevator may be dispensed with and the sifted material be conveyed to the hopper of the first separator in any convenient manner.

What I claim is—

1. In an electro-magnetic separator, a mag-

net having its poles or polar extensions or faces in different planes relatively to the path of the material to be treated, substantially as set forth.

2. The combination of a series of magnetic separators acting successively upon the same stream of material and arranged to change the trajectory of the magnetic portion of the falling material without stopping its fall, and a series of hoppers acting as hoppers and waste-chutes, the hopper of one separator being the waste-chute of another, substantially as set forth.

3. The combination of a series of magnetic separators, each arranged to change the trajectory of the magnetic portion of the falling material without stopping its fall, such magnetic separators being located successively nearer the path of the material to be acted on, substantially as and for the purpose set forth.

4. The combination of a sieve, an elevator, a series of electro-magnetic separators, constructed substantially as shown, and a single delivery-chute, substantially as set forth.

This specification signed and witnessed this 26th day of July, 1880.

THOS. A. EDISON.

Witnesses:

WM. CARMAN,
S. D. MOTT.