

(No. Model.)

T. A. EDISON.
MAGNETIC SEPARATOR.

No. 377,518.

Patented Feb. 7, 1888.

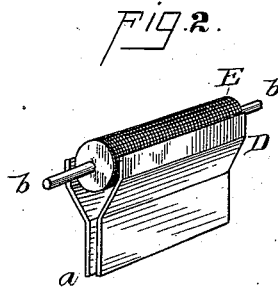
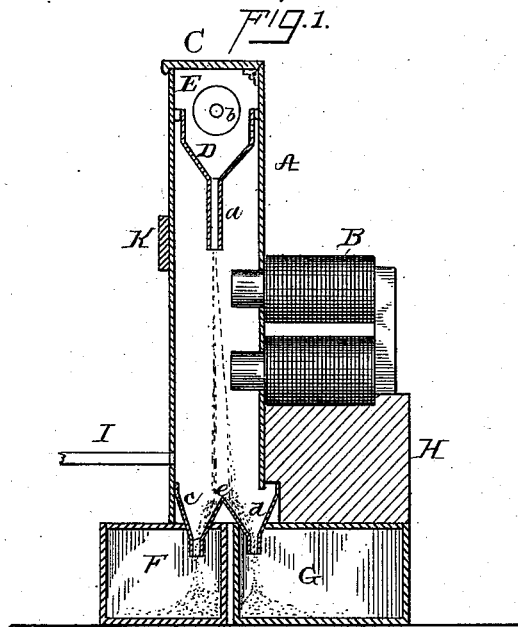

ATTEST:
Ed. Rowland
Wm. Oyer

INVENTOR:
Thomas A. Edison
By [Signature]
Attorney

UNITED STATES PATENT OFFICE.

THOMAS A. EDISON, OF LLEWELLYN PARK, NEW JERSEY.

MAGNETIC SEPARATOR.

SPECIFICATION forming part of Letters Patent No. 377,518, dated February 7, 1888.

Application filed July 6, 1887. Serial No. 243,490. (No model.)

To all whom it may concern:

Be it known that I, THOMAS A. EDISON, of Llewellyn Park, in the county of Essex and State of New Jersey, have invented a certain new and useful Improvement in Magnetic Separators, (Case No. 725,) of which the following is a specification.

My invention relates to magnetic separators in which the separation of magnetic from non-magnetic particles is accomplished by permitting them to fall together past the poles of a magnet, which alters the trajectory of the magnetic particles, so that they fall separately from the non-magnetic ones.

The object of my invention is to cause the material to fall in a straight and even stream past the magnet-poles and to prevent the particles from being affected by drafts of air.

To this end my invention consists partly in the use of a closed air-chamber, through which the material is caused to fall, whereby it is protected from air-currents, and also in the use of such closed air-chamber when it has its atmosphere rarefied or a portion of its air removed, which is advantageous in the case of very light or finely-divided material, as the rarefied atmosphere will not affect the direction of falling of the particles.

In addition to these features of invention, my invention consists in the various novel devices employed by me in accomplishing the above-named object, as hereinafter set forth and claimed.

My invention is illustrated in the accompanying drawings, in which—

Figure 1 is a view in elevation of apparatus embodying my invention, with the chamber in section; and Fig. 2, a perspective view of the feeding device.

A is a box, chamber, or shaft, preferably made of wood. B is a powerful electro-magnet placed outside of said chamber, but preferably with its poles extending through into the chamber. The top of the chamber is closed by a hinged cover, C. Within the chamber, near its top, is supported a hopper, D, which is a box with inclined sides and with a straight-sided narrow feeding-passage, *a*, at its bottom. Within the hopper, or immediately above it, is placed a cylindrical sieve, E, on a shaft, *b*, which turns in bearings in the

walls of the chamber and may be revolved in any suitable way. At the lower end of the chamber are two inclined troughs, *c* and *d*, with open bottoms, opening, respectively, into closed bins or receptacles F and G. The dividing-point *e* between the troughs is to one side of the feed-passage *a*, so that material falling straight from said passage enters the bin F. The magnet B has a support, H, or is otherwise supported with its poles a little below the feeding-passage *a*.

The mixture of finely-divided magnetic and non-magnetic material, which may be of gold mixed with iron particles, or of iron and sand, is placed in the sieve E, and on the same being revolved the fine particles are fed from the sieve, those which are too coarse to be effectively operated upon being retained thereby. The narrow straight-sided feeding-passage causes the material to assume a straight course in falling from the hopper. It thus falls in the closed air-chamber straight past the poles of the magnet and the attraction of the magnet alters the trajectory of the magnetic portion of the stream, so that this falls separately from the rest and enters the trough *d* and bin G. Being in a closed space, there can be no drafts of air which would alter the direction of either of the falling streams and prevent the particles from reaching their respective receptacles. If the particles are very fine or light, as where the material must be ground very fine to liberate the gold, I prefer to exhaust or rarefy the air in the chamber, so that the resistance of the air will not affect its fall. When it is desired to do this, suitable rubber packing is provided for the cover C and around the poles of the magnet, and stuffing-boxes for the shaft of the feeding-sieve, so that the chamber is made sufficiently air-tight. A pipe, I, extends from the chamber, which is connected to an ordinary steam vacuum apparatus by which the air is exhausted, say to a twenty-nine-inch column of mercury, which is sufficient for the purpose.

Since it is necessary or desirable that the poles of the magnet should be near the end of the feeding-passage *a*, the attraction might draw the magnetic particles to one side of the passage and cause the clogging of the opening. To obviate this I place upon the wall of the

chamber, opposite the end of the feeding-passage, a heavy piece of iron, K, whose counter attraction holds the particles straight in the passage, so that they have the proper vertical direction when they leave the same.

5 What I claim is—

1. In a magnetic separator, the combination of a closed air-chamber, feeding devices at the top of the chamber and receptacles at the bottom, and a magnet for altering the trajectory of falling magnetic particles in said chamber, substantially as set forth.

2. The method of separating magnetic from non-magnetic materials, consisting in causing the mingled materials to fall past the poles of a magnet in a closed chamber from which a portion of the air has been removed, whereby the trajectory of the magnetic material is altered, substantially as set forth.

3. In a magnetic separator, the combination of a closed chamber from which a portion of the air is exhausted, feeding devices at the top

of the chamber and receptacles at the bottom, and a magnet for altering the trajectory of falling magnetic particles in said chamber, 25 substantially as set forth.

4. In a magnetic separator, the combination, with the horizontally-placed magnet, of the narrow straight-sided feeding-passage above said magnet, whereby the material is delivered 30 past the poles of said magnet in a thin stream, substantially as set forth.

5. In a magnetic separator, the combination, with the feeding-passage, of the magnet below the same on one side, and an opposing magnetic 35 device on the other side of said passage, substantially as set forth.

This specification signed and witnessed this 30th day of June, 1887.

THOS. A. EDISON.

Witnesses:

WILLIAM PELZER,
E. C. ROWLAND.