

(No Model.)

T. A. EDISON.

FEED AND RETURN MECHANISM FOR PHONOGRAPHS.

No. 382,416.

Patented May 8, 1888.

Fig. 1.

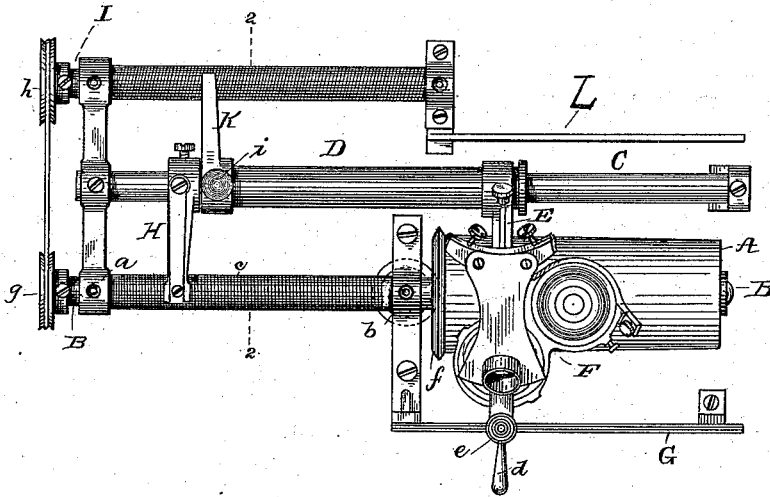

Fig. 2.

Fig. 3.

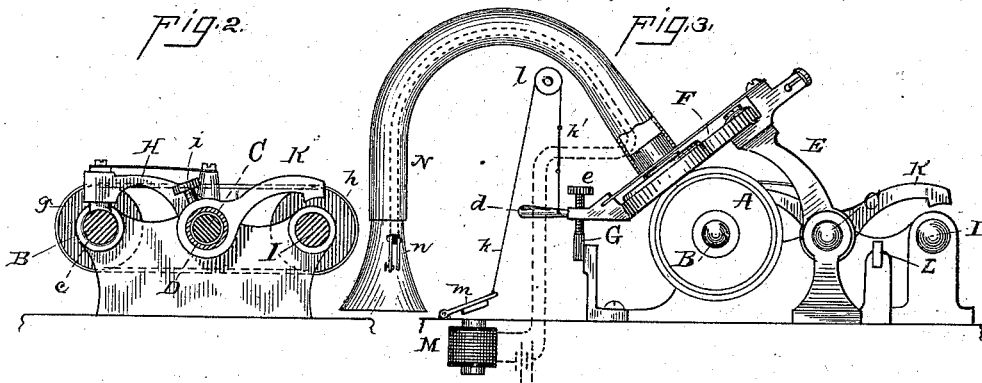
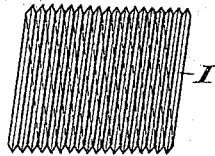

Fig. 4.



Witnesses,
E. S. Fowland,
T. M. Witherspoon.

Inventor,
Thomas A. Edison,
By his Attorneys *Dyer & Seely.*

UNITED STATES PATENT OFFICE.

THOMAS A. EDISON, OF LLEWELLYN PARK, NEW JERSEY.

FEED AND RETURN MECHANISM FOR PHONOGRAPHS.

SPECIFICATION forming part of Letters Patent No. 382,416, dated May 8, 1888.

Application filed January 5, 1888. Serial No. 259,897. (No model.)

To all whom it may concern:

Be it known that I, THOMAS A. EDISON, of Llewellyn Park, in the county of Essex and State of New Jersey, have invented a certain
5 new and useful Improvement in Phonographs, (Case No. 745,) of which the following is a specification.

The object I have in view is to produce a simple and efficient mechanism for setting back
10 automatically on the depression of a key or treadle the reproducer of a phonograph for reproducing the whole or a portion of the record. This I desire to do without reversing the motion of the lead-screw and by a movement
15 which lifts the reproducer from the surface of the phonogram. I accomplish this end by means of a screw-shaft revolving with the lead-screw and engaging when the reproducer is lifted from the phonogram-surface an arm on
20 the guide-sleeve and moving such guide-sleeve back with a rapid motion.

To give rapidity to the movement, the retracting-screw is composed of a number of parallel threads which are as fine as the threads
25 of the lead-screw, so that the arm will engage at any point, but, by reason of having a number of parallel threads, can be given a much greater pitch than the threads of the lead-screw. The rocking holding-arm carrying the reproducer
30 is connected through a cord preferably having an elastic section with a lever, which may be a key or treadle, so that by striking the key or treadle the parts will be set back, or an electro-magnet can be used to lift the rocking
35 holding-arm. The arm that engages with the retracting-screw is held by a set-screw and can be set up out of action, or can be adjusted and held so as to engage the retracting-screw the moment the guide arm is released from
40 the lead-screw.

In the accompanying drawings, forming a part hereof, Figure 1 is a top view of parts of a phonograph, illustrating my invention; Fig. 2, a cross section through the leading and retracting screws on the line 2 2, looking at the
45 engaging-arms; Fig. 3, an elevation from the outer end of the phonogram-cylinder, and Fig. 4 a separate enlarged view of a portion of the retracting-screw.

50 A is the phonogram-cylinder, mounted on a shaft, B, held by bearings *a b*. Between these

bearings the shaft is cut with a fine screw-thread, forming the lead-screw *c*. In rear of the cylinder A and shaft B is the guide-rod C, upon which is mounted the guide-sleeve D. 55 This guide-sleeve D slides on the guide-rod C, as will be understood. At one end of the sleeve D the rocking holding-arm E rises therefrom, carrying the swinging spectacles F, in the eyes of which are the recorder and repro- 60 ducer. The spectacles have fingers *d* and set-screws *e*, which bear upon the guide-rest G. The guide-sleeve D has at its other end a guide-arm, H, with a screw-threaded end, which engages the lead-screw *c*. The cylinder 65 A and shaft B being revolved from a motor by means of a soft bevel-wheel bearing on the bevel-flange *f* of the cylinder, the guide-sleeve D and the rocking holding-arm E, with the recorder and reproducer, are advanced from the 70 left to the right, as seen in Fig. 1.

In rear of the guide-rod C, and parallel therewith and with the cylinder-shaft B, is a shaft, I, mounted in suitable bearings on the frame and revolved by a small round belt passing 75 over wheels *g h* on the ends of this shaft and the cylinder-shaft. The shaft I is a screw cut with three parallel threads, which are as fine as the single thread of the screw *c*, but have a greater pitch. An arm, K, projects rearwardly 80 from the guide-sleeve D and has a corresponding screw cut on its end to engage with the screw-shaft I. The arm K is secured to the sleeve D by a set-screw, *i*, so that it can be turned upon such sleeve and held at any point 85 of adjustment. This permits the arm K to be thrown up out of the way and held by the set-screw, so that the rocking holding-arm E can be thrown over onto the back rest, L, without engaging the arm K with the screw-shaft I, or 90 the arm K can be fixed at such a point that it will engage the screw-shaft I as soon as the guide-arm H is released from the lead-screw *c*. The arm K will engage the multiple thread of the shaft I at any point that the guide-arm 95 H is released from the single thread of the screw *c*, because the threads are of equal fineness; but the screw-shaft I will retract the parts with much greater speed than the screw *c* feeds them forward by reason of its greater 100 pitch, permitted by the use of a number of threads.

- For lifting the reproducer from the phonogram and causing the arm K to engage the screw-shaft I, I connect the finger *d* of the eye of the spectacles carrying the reproducer with a cord, *k*, passing up over a wheel, *l*, and down to a lever, *m*, which may be a hand-key or foot-treadle. This cord preferably has an elastic section, *k'*, which will yield to permit the retracting movement of the reproducer.
- 10 An electro-magnet, M, acting on an armature on the lever *m* and controlled by a circuit-controller, *n*, on the listening-tube N, may be used for lifting the rocking holding-arm to set it back.
- 15 What I claim is—
1. In a phonograph, the combination, with the rocking holding-arm carrying the reproducer, of a revolving screw-shaft and an arm connected with the rocking holding-arm and engaging this screw-shaft when the rocking holding-arm is rocked to lift the reproducer from the phonogram, whereby the reproducer is retracted or set back, substantially as set forth.
- 25 2. In a phonograph, the combination, with the phonogram - cylinder, the lead-screw, and holding and guide arms, of a revolving screw-shaft having a screw of greater pitch than the lead-screw, and an arm engaging this screw-shaft when the guide-arm is raised from the lead-screw, substantially as set forth.
- 30 3. In a phonograph, the combination, with the phonogram-cylinder, the lead-screw, and holding and guide arms, of a revolving screw-shaft having a screw composed of a number of threads of greater pitch than the lead-screw, and an arm engaging this screw-shaft when the guide-arm is raised from the lead-screw, substantially as set forth.
- 35 4. In a phonograph, the combination, with the phonogram-cylinder, the lead-screw, the guide-sleeve, and the holding and guide arms,
- 40

of the retracting-screw shaft and the arm engaging therewith fixed adjustably upon the guide-sleeve, substantially as set forth. 45

5. In a phonograph, the combination, with the phonogram-cylinder, the lead-screw, the guide-sleeve, and the holding and guide arms, of the retracting-screw shaft driven by a belt from the cylinder-shaft, and the arm engaging therewith fixed adjustably upon the guide-sleeve, substantially as set forth. 50

6. In a phonograph, the combination, with the rocking holding-arm, the lead and retracting screws, and the arms engaging such screws alternately, of a lever connected by an elastic lifting-cord with such rocking holding-arm to rock and set back the holding-arm, substantially as set forth. 55

7. In a phonograph, the combination, with the rocking holding-arm carrying the reproducer or recorder, of an electro-magnet and armature acting to lift such arm and disengage the reproducer or recorder from the phonogram-surface, substantially as set forth. 60 65

8. In a phonograph, the combination, with the rocking holding-arm carrying the reproducer or recorder and the lead-screw, of an electro-magnet and armature acting to lift such arm, disengaging it from the phonogram and from the lead-screw, substantially as set forth. 70

9. In a phonograph, the combination, with the rocking holding-arm carrying the reproducer or recorder and the lead and retracting screws, of an electro-magnet and armature acting to lift such arm, disengaging it from the lead-screw and connecting it with the retracting-screw, substantially as set forth. 75

This specification signed and witnessed this 29th day of November, 1887.

THOS. A. EDISON.

Witnesses:

WILLIAM PELZER,
E. C. ROWLAND.