

(No Model.)

T. A. EDISON.

AUTOMATIC DETERMINING DEVICE FOR PHONOGRAPHS.

No. 406,575.

Patented July 9, 1889.

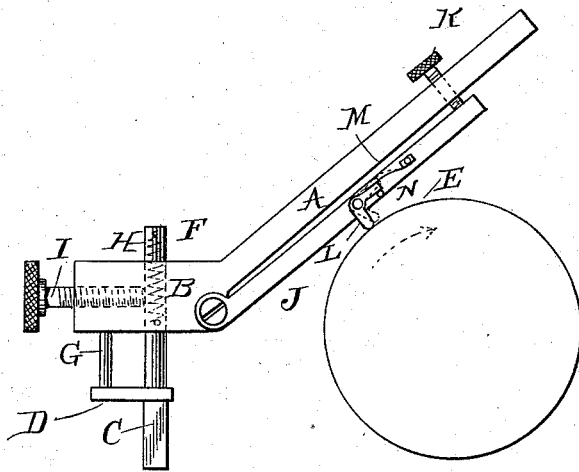

ATTEST:

Ed. Rowland
N. H. Driscoll

INVENTOR:

Thomas A. Edison
By [Signature]
Attorn

UNITED STATES PATENT OFFICE.

THOMAS A. EDISON, OF LLEWELLYN PARK, NEW JERSEY.

AUTOMATIC DETERMINING DEVICE FOR PHONOGRAPHS.

SPECIFICATION forming part of Letters Patent No. 406,575, dated July 9, 1889.

Application filed February 11, 1889. Serial No. 299,460. (No model.)

To all whom it may concern:

Be it known that I, THOMAS A. EDISON, a citizen of the United States, residing at Llewellyn Park, in the county of Essex and State of New Jersey, have invented a new and useful Improvement in Automatic Determining Devices for Phonographs, (Case No. 828,) of which the following is a specification.

In my application, (Case No. 818,) Serial No. 296,420, filed January 15, 1889, I have described a preferred form of device for determining automatically the exact position of the recording and reproducing points on the phonogram-cylinder, whether thick or thin, and referred in general terms to other forms of device to accomplish the same purpose which I had tried.

My present invention relates to an automatic determining device employing a pivoted determining-point adapted to be rocked or canted by the rotation of the phonogram-blank to enable it to ride lightly over the surface of said blank without mutilating the same; and my invention consists in the devices and combinations of parts hereinafter explained, and pointed out by claims.

In the accompanying drawing, forming a part hereof, the single figure represents a side elevation of a form of device embodying my invention, the pivoted determining-point being shown in full lines in determining contact with the phonogram-blank and in broken lines in the position it assumes when the blank is rotated in the direction of the arrow.

A represents the spectacle-frame carrying the recorder and reproducer. It is similar in construction and mode of operation to the spectacle-frame described in my application above referred to. It has attached to it two arms, but one of which B is shown in the drawings, one arm for each eye of the frame. These arms project forward over the guide-rest C, and each arm is provided with a presser-foot D, which bears upon the guide-rest and supports the spectacle-frame as it moves in a definite relation to the phonogram-blank E.

The presser-foot D is a plate mounted upon the lower end of a bar F, which passes up through the arm B, said plate being provided also with a pin G, to prevent its turning on the guide-rest. A spring H is connected to a pin at the upper end of the bar F and with another

pin upon the side of the arm B, and, drawing downwardly upon the bar F, tends to project the presser-foot downwardly to the lowermost limit of its movement.

I is the locking-bolt, which is operated by hand after the determining-point has come in contact with the phonogram-blank, to lock the parts in the determined position.

Pivoted to the arm B is a lever J, upon the free end of which a set-screw K bears to adjust the lever as may be found necessary. On the lever J is pivoted an L-shaped rocking piece L, one arm of which forms the determining-point and the other arm of which is acted on by a flat spring M to throw the arm forming the determining-point into a perpendicular relationship with the phonogram-blank when the blank ceases to revolve. A pin N serves to limit the movement of the rocking arm away from the blank.

In operation, as the spectacle-frame is lowered, the bar F will be projected to its lowermost position with reference to the bar B by the tension of the spring H. As soon as the presser-foot mounted on the bar F strikes the guide-rest its motion is arrested, but the downward motion of the spectacle-frame continues against the tension of the spring H, thereby producing an easy motion, which is communicated to the determining-point, thereby obviating a jarring contact of the determining-point and phonogram-blank, which might result in injury to the blank. The rocking determining-point is now in the perpendicular position shown in full lines in the drawing. The descent of the spectacle-frame will bring the determining-point into contact with the phonogram-cylinder. When this occurs, the operator locks the parts in this position by means of the locking-bolt I, and the cylinder is set in operation. The revolving cylinder, with which the determining-point is in contact, cants the piece bearing that point into the position shown in dotted lines in the drawing and the determining-point will ride over the surface of the phonogram-blank lightly without mutilating it. As soon as the spectacle-frame is raised from the phonogram-blank the spring M throws the determining-point into the perpendicular, ready to effect a new determination.

What I claim is—

1. In a phonograph, the combination, with
a movable frame, a guide-rest, and adjustable
presser-foot, of a pivoted determining-point
adapted to ride in a canted position on the
5 surface of a revolving phonogram, substan-
tially as specified.

2. In a phonograph, the combination, with
a movable frame, a guide-rest, and adjustable
presser-foot, of a pivoted L-shaped piece, one
10 arm of which forms a determining-point, and
the other arm of which is operated upon by a
spring to throw the determining-point into
the perpendicular when the phonogram ceases
to revolve, and said spring, substantially as
15 specified.

3. In a phonograph, the combination, with
a movable frame, a guide-rest, and adjustable
presser-foot, of a pivoted determining-point

adapted to ride in a canted position on the
surface of a revolving phonogram, and a lock 20
locking the movable frame, operated by hand
after the determining-point comes in contact
with the phonogram, substantially as speci-
fied.

4. In a phonograph, the combination, with 25
a movable frame, a guide-rest, and adjustable
presser-foot, of a lever bearing a pivoted de-
termining-point and an adjusting-screw for
said lever, substantially as specified.

This specification signed and witnessed this 30
1st day of February, 1889.

THOMAS A. EDISON.

Witnesses:

W. PELZER,

D. H. DRISCOLL.