

(No Model.)

T. A. EDISON.
AUTOMATIC DETERMINING DEVICE FOR PHONOGRAPHS.
No. 426,527. Patented Apr. 29, 1890

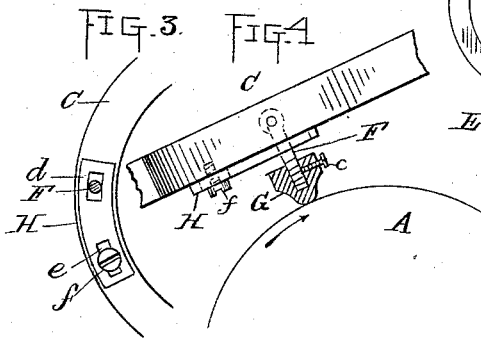
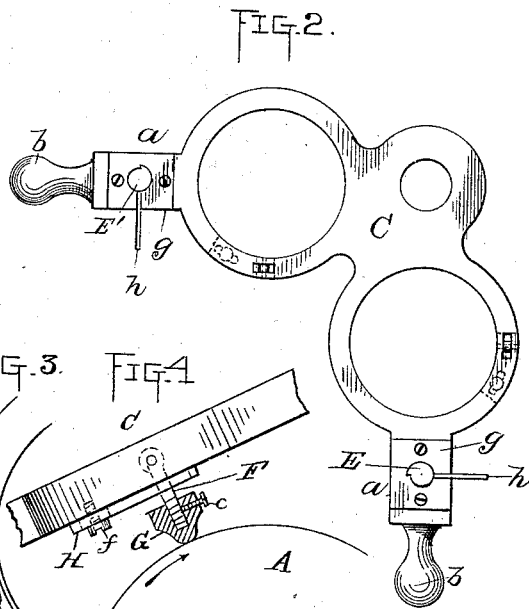
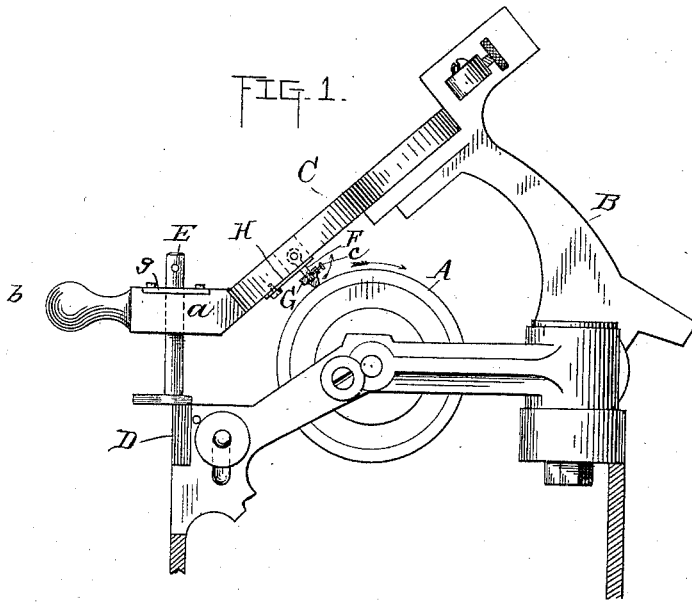

Witnesses
E. W. Rowland
W. F. Feyer

Inventor
Thomas A. Edison
By his Attorneys
John F. ...

UNITED STATES PATENT OFFICE.

THOMAS A. EDISON, OF LLEWELLYN PARK, NEW JERSEY.

AUTOMATIC DETERMINING DEVICE FOR PHONOGRAPHS.

SPECIFICATION forming part of Letters Patent No. 426,527, dated April 29, 1890.

Application filed July 2, 1889. Serial No. 316,323. (No model.)

To all whom it may concern:

Be it known that I, THOMAS A. EDISON, a citizen of the United States, residing at Llewellyn Park, in the county of Essex and State of New Jersey, have invented a new and useful Improvement in Automatic Determining Devices for Phonographs, (Case No. 835,) of which the following is a specification.

As is well understood, my phonograph is provided with a device by which the relation of the recorder or reproducer with the surface of the phonogram-blank can be accurately determined and the presser-foot then locked, so that as it moves along on the guide-rest the correct position of the recorder or reproducer with reference to the surface is maintained.

My present invention relates to devices of this character and employs a pivoted determining-point which is rocked or canted by the rotation of the phonogram-blank, so as not to impair the surface. Such a determining-point is described and broadly claimed in my application, (Case No. 828,) Serial No. 299,460, filed February 11, 1889.

My improvement in respect to this part of the device consists in a simplification of the rocking determining-point and the providing of it with better means of adjustment, as will presently appear.

A further feature of improvement is the means for locking the presser-foot by a cam-movement, which is readily thrown into and out of action and gives a positive lock entirely independent of the finger-pieces for raising and lowering the spectacle-frame.

In the accompanying drawings, forming a part hereof, Figure 1 is an end view of sufficient of the phonograph to illustrate the invention, the adjustable head to the rocking determining-point being in section. Fig. 2 is a top view of the spectacle-frame detached. Fig. 3 is a bottom view of a portion of spectacle-frame, showing the adjustable limiting-plate; and Fig. 4 is an enlarged view of the determining-point.

A is the revolving phonogram-surface.

B is the rocking holding-arm, carrying the swinging spectacle-frame C.

D is the guide-rest, and E E' are the presser-foot bars, which pass through the fingers *a* of the spectacle-frame, such fingers termin-

ating in knobs *b* for raising and lowering and swinging the frame.

Instead of mounting the rocking determining-point upon a bar pivoted to the spectacle-frame, as described in the application before referred to, each determining-point is composed of a bolt F, which is pivoted directly in the spectacle-frame, the bolt having an eye in its upper end, entering a slot in the spectacle-frame from the under side of the frame and pivoted therein by a cross-pin. One of these bolts is provided for each eye of the spectacle-frame, so as to provide the means for adjusting both the recorder and reproducer with reference to the phonogram-surface. The end of the bolt F is screw-threaded, and upon it turns a head G, which has a rounded polished surface (formed on a curve of which the pivot of the bolt is the center) and is secured from turning on the bolt by means of a set-screw *c*. By turning the head G upon the bolt F the bolt is shortened or lengthened, and a fine adjustment is thus secured, which is maintained by setting the screw *c*. The bolt F passes through a slot *d* in a plate H, secured to the under side of the spectacle-frame by means of a slot *e* and a screw *f*, so that said plate H can be adjusted. The slot *d* in the plate H limits the swinging movement of the determining-point. Since the swinging bolt F is oblique to a vertical line, it will swing by its own weight against the lower side of the slot *d* in the plate H, and it is in this position that the head G strikes the surface of the phonogram-blank and determines the adjustment.

The presser-foot bars E E' are made of a cam shape, and upon the top of the fingers *a* are provided plates *g*, which have a similar cam-shaped opening, through which the presser-foot bars pass. This cam is of a spiral shape, so that a slight turning movement of the presser-foot bars will lock them in the plate *g*. A pin *h* projects from the top of each presser-foot bar, by which it is turned to lock or unlock it in the plate *g*. When unlocked, the presser-foot bars fall through the fingers *a* of the spectacle-frame by gravitation or by means of springs, as in the former devices employed by me.

The operation of performing the adjustment is as follows: The rotating movement

of the phonogram-surface is arrested and the spectacle-frame is lowered, the presser-foot bar being free in the finger of the frame and projecting downwardly to its lowermost limit.

5 The presser-foot first strikes the guide-rest D, and as the downward movement of the frame continues the finger of the spectacle-frame slides down over the presser-foot bar. The head G strikes the surface of the phonogram-blank, arresting the further downward movement of the spectacle-frame and determining its point of adjustment with relation to the surface. The pin *h* is then drawn slightly toward the operator and locks the
10 presser-foot bar positively in the finger of the spectacle-frame. Now, when the phonogram-blank begins to rotate in the direction shown by the large arrow in Fig. 1 the determining-point, being pivoted, will rock
15 slightly upon its pivot and relieve the surface of injurious pressure.

The simple cam-locking device operated by a partial rotation of the presser-foot bar is an exceedingly effective lock, and might be
25 used with other forms of determining-point. If the bar is locked by a turning screw which forms the end of the finger of the spectacle-frame, as in the application referred to, there is a tendency to move the spectacle-frame in
30 turning the locking-screw, usually by exerting an additional downward pressure upon it. The proper adjustment being such that the turning-off tool of the phonograph will enter the phonogram-surface only to the extent of
35 two one-thousandths of an inch, it will be seen that even a slight pressure may result in forcing the determining-point into the surface far enough to destroy the accuracy of the adjustment. The cam-lock being a locking
40 device whose movement by the fingers of the operator is independent of the movement of the spectacle-frame in the sense that it does not tend to disturb the position of the spectacle-frame or exert strain upon it, an entirely accurate adjustment can be readily secured without the exercise of extreme care.

Any suitable arrangement of a locking-cam operated by a separate finger-piece can be used. Many such differing in detail from
50 that shown and described would occur to the skilled mechanic.

What I claim as my invention is—

1. In a phonograph, the combination, with

the spectacle-frame, of the determining-point pivoted directly upon such frame, substantially as set forth. 55

2. In a phonograph, the combination, with the spectacle-frame, of a pivoted determining-point pivoted directly upon said frame and having an adjustable head, substantially as set forth. 60

3. In a phonograph, the combination, with the spectacle-frame, of a pivoted determining-point and an adjustable limiting-plate for limiting the swinging movement of the
65 point, substantially as set forth.

4. In a phonograph, the combination, with the spectacle-frame presser-foot bar, and guide-rest, of a lock the movable element of which is carried by the presser-foot bar, operated independently of and without exerting
70 any strain upon the spectacle-frame for fixing the position of said spectacle-frame on the presser-foot bar, substantially as set forth.

5. In a phonograph, the combination, with
75 the spectacle-frame, presser-foot bar, and guide-rest, of a cam-lock the movable element of which is carried by the presser-foot bar, operated independently of and without exerting any strain upon the spectacle-frame
80 for fixing the position of said spectacle-frame on the presser-foot bar, substantially as set forth.

6. In a phonograph, the combination, with
85 the spectacle-frame, of a cam-shaped presser-foot bar passing through a cam-shaped opening in the finger of the spectacle-frame and locked therein by partial rotation, substantially as set forth.

7. In a phonograph, the combination, with
90 the spectacle-frame, presser-foot bar, and guard-rest, of a determining-point pivoted directly upon the spectacle-frame and a lock the movable element of which is carried by the presser-foot, operated independently of
95 and without exerting any strain upon the spectacle-frame for fixing the position of said spectacle-frame on the presser-foot bar with relation to the position of the determining-point, substantially as set forth. 100

This specification signed and witnessed this 15th day of June, 1889.

THOS. A. EDISON.

Witnesses:

WILLIAM PELZER,
RICHD. N. DYER.