

(No Model.)

T. A. EDISON.
PHONOGRAPH.

No. 430,278.

Patented June 17, 1890.

FIG. 1.

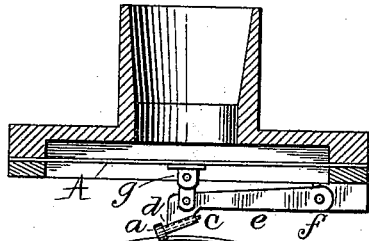

FIG. 2.

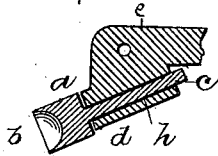

FIG. 4.

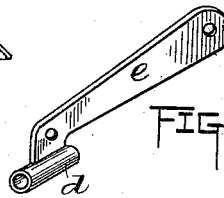

FIG. 3.

FIG. 5.

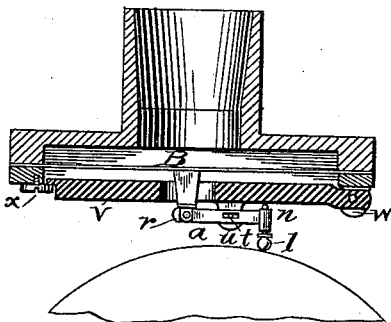

FIG. 6.

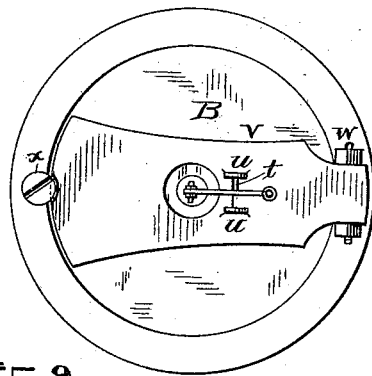

FIG. 7.

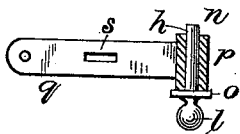
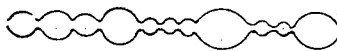

FIG. 9.



Witnesses
E. C. Howland
William R. Ryan

FIG. 8.



Inventor
Thomas A. Edison

By his Attorneys

John P. ...

UNITED STATES PATENT OFFICE.

THOMAS A. EDISON, OF LLEWELLYN PARK, NEW JERSEY.

PHONOGRAPH.

SPECIFICATION forming part of Letters Patent No. 430,278, dated June 17, 1890.

Application filed April 10, 1889. Serial No. 306,670. (No model.)

To all whom it may concern:

Be it known that I, THOMAS A. EDISON, a citizen of the United States, residing at Llewellyn Park, in the county of Essex and State of New Jersey, have invented a certain new and useful Improvement in Phonographs, (Case No. 833,) of which the following is a specification.

This invention relates to the recording and reproducing points of the phonograph, and has for its objects such an improvement in the form and construction of such devices and in the manner of arranging and supporting the same as, in the first place, to materially improve the character of the sounds produced by the instrument, so as to make them more accurately reproduce the sound-vibrations communicated to the recorder than has heretofore been found possible; secondly, to make the instrument of a less delicate character and more readily manipulated and adjusted by inexperienced persons, and, thirdly, to enable the recording-point to be used for a longer period of time without having to be sharpened or reground or replaced by another.

One feature of my invention consists in the use of a recording-point having a cutting-edge, which is a portion of the edge of a cylinder and forms a gouging-edge, or one which cuts a rounded groove, so that the indentations due to the movements of such point are circular and with curved sides sloping to the center instead of square, and with straight sides, such as are produced by the straight-edged cutting-points which have heretofore been used. I prefer to employ a recording-point whose end is formed into a complete circular edge—that is to say, the end of a cylindrical head is cupped or hollowed out so as to produce a thin circular cutter, so that when one part of the edge becomes worn or dulled the stem may be turned and a different part of the circumference or a new curved cutting-edge is brought into position to operate on the phonogram-blank. To readily accomplish this and also to produce a means of holding the recording-point which shall enable the latter to be readily removed and easily replaced in position by unskilled persons, I provide the point with a shank which

is inserted into a socket and held therein removably, preferably by means of a little cement, which can be readily softened by heat, such as a small quantity of shellac. I prefer to support the reproducing-point in the same way, so that it also can be readily removed and replaced when necessary. I employ, also, a reproducing-point having a convex circular bearing-surface—that is to say, a bearing-surface which is the surface of a portion of a sphere. I prefer to employ as a reproducing-point a ball or sphere at the end of a suitable stem. This is supported so that it has a slight movement laterally of the record, and when traveling in the circular depressions formed by the recording-point it fits such depressions, and even if the lever which carries it is out of line with the record, so that the ball does not stand vertically in the record, or if it bears against the curved sides of the depressions, it reproduces the vibrations with the same exactness. The effect of the weight of the reproducing-point and attached parts is such, however, that the point always tends to go to the bottom or center of a depression. With the curved recording-point the whole depression forms the record of the sound-wave, and not only the bottom of it as with a straight recording-point, so that if the spherical reproducer touches the surface of the depression at any point it gives an accurate reproduction.

If a straight-sided reproducing-point gets out of line or tilted laterally, it does not reproduce accurately, and with straight-sided depressions if the reproducing-point bears against the sides it does not reproduce perfectly and it cuts through the sides and scrapes against them so as to produce imperfect articulation and injure the record itself.

My invention is illustrated in the accompanying drawings, in which—

Figure 1 is a section of the case and mouth-piece of the recorder with the recording-point and attached parts shown in elevation and with the point itself on an enlarged scale; Fig. 2, a longitudinal section of the recording-point and holder therefor; Fig. 3, a perspective view of the holder and the lever which carries it; Fig. 4, a perspective view of a modified form of recording-point; Fig. 5, a

view of the reproducer, similar to Fig. 1; Fig. 6, a bottom view of the reproducer; Fig. 7, a side elevation of the reproducing-point and the parts which hold and support it, the tubular holder being shown in vertical section; Fig. 8, a view of a modified form of reproducing-point; and Fig. 9, an illustration of the form of the record produced by the arc-shaped recording-point, the view being of the character of a plan view.

The recording-point consists, preferably, of a cylindrical piece *a*, whose end is hollowed or cupped out, as illustrated in Fig. 2, so that a very fine and sharp circular edge *b* is formed. From the part *a*, which is the head of the recording-tool, a shank *c* extends, which is preferably round, and which enters a tubular holder *d*, attached by soldering or otherwise to the lower side of the usual lever *e*, pivoted at *f* on the rim of the reproducer, and connected at *g* with the center of the diaphragm A. Preferably the shank *c* is cemented in the holder *d* by the application of a little shellac or other suitable material *h*, which can readily be softened by heating it; but instead of this the secure removable attachment of the shank in the sleeve may be attained by suitable mechanical holding devices of various kinds, as will readily be seen.

It will be seen that only the lower portion of the circular tool meets the surface of the phonogram-blank, so that the cutting-edge in use at any time is shaped as the arc of a circle whose center is outside of the recording-surface. The circle of the cutting-edge is in practice exceedingly small, being necessarily exaggerated for illustration in the drawings. For a phonograph which has one hundred threads to the inch on its feed-screw, I prefer to make the diameter of the circular cutting-tool about forty-thousandths of an inch. It is of course not necessary for the production of the peculiar character of record desired that the edge shall be a complete circle. It may be a semi-circle or other portion of a circle, as illustrated in Fig. 4, in which the head *i* is formed at its lower side only with a cutting-edge *k*, shaped as the arc of a circle whose center is outside the recording-surface and provided like the other with a shank *c* for insertion in the holder. But by making it circular I provide several curved cutting-edges—two or more—and I enable the same recording-point to be used for a much longer time without having to be replaced or sharpened, for when any portion of the edge has been used long enough to become worn or dulled the cement in the holder may be softened by the application of a low degree of heat and the shank turned in the holder or withdrawn and inserted in a different position, so as to bring a fresh arc-shaped cutting-edge into operative position, and this may be repeated several times before the whole circumference has been used. It will be seen that this is an operation which does not require especially skillful manipulation, but

can readily be performed by any one, and this is an important advantage because the phonograph must necessarily be placed usually in the hands of unskilled and inexperienced persons. The advantages of the peculiar form of holder are, however, not confined to its use with the circular cutting-edge, for this evidently is a desirable form of holder for recording and reproducing points of any character when the same are provided with shanks or extensions capable of being inserted and held in the holder, since it enables such recording or reproducing points to be readily removed and replaced by any one without the exercise of any especial skill or knowledge and without any delicate adjustment, the parts being so arranged that when the head or other enlarged portion meets the holding-sleeve, the point is in the proper position for operation. It is evident, also, that the holding-sleeve and shank are not necessarily round in cross-section, since the same may readily be made square or of other polygonal shape. Of course in this case the shank cannot be turned in the sleeve; but it can readily be withdrawn, turned, and replaced in a new position.

The character of the record produced by the curved or arc-shaped cutting recording-tool is indicated in Fig. 9. It will be seen that such record takes the form of a series of circular pits or depressions whose walls curve toward the center or bottom point, and that the width of such depressions is in proportion to their depth, and also that every portion of each depression contains the record of the sound-wave, so that if the reproducer enters the depression and touches at any point it will receive the required movement corresponding to the impressed sound-wave.

The head of the reproducing-point is preferably a ball or sphere *l*, but it may be only a portion *m* of the sphere, as illustrated in Fig. 8. Such head preferably has a shank *n*, provided with a flange *o*, and such shank enters the holding-sleeve *p* until the flange meets the holder and is secured preferably in the same manner as hereinbefore described with reference to the recording-point—that is to say, by a small quantity of shellac or similar cement *h*, or screwed in.

The holder *p* is attached to or made in one piece with a lever *q*, which is connected at *r* in the usual manner by a hinge with the center of the reproducing-diaphragm B. The lever *q* has a slot *s*, and through such slot passes a pin *t*, extending between lugs *u*, which depend from a plate *v*, pivoted at *w* on the rim of the reproducer and kept from falling out of place by the head *x* of the screw on the opposite side of the rim from the pivot. The plate *v* forms a weight which bears on the reproducing-point and tends to force the same always to the bottom of the recorded indentations, the slot *s* allowing a slight lateral rocking movement of the reproducing-point so that if the lever is out of line with the record the point itself can rock into the

required position, and its having a rounded bearing-surface makes it immaterial whether it stands straight in the depression or is inclined toward one side thereof. The weight *v* also forms a retarding device, such as is described and claimed in my patent, No. 397,280, dated February 5, 1889, since it does not move under the quick vibrations communicated to the reproducing-point by the sound-record, but under slow movements due to irregularities or inaccuracies of the surface of the phonogram or eccentric movements of rotation it yields and permits the reproducing-point to conform to such irregularities.

15 What I claim is—

1. In a phonograph, the combination, with a diaphragm, of a recording-point carried thereby having a curved cutting-edge, substantially as set forth.

20 2. In a phonograph, the combination, with a diaphragm, of a recording-point carried thereby having a circular cutting-edge, substantially as set forth.

3. In a phonograph, the combination, with a record-surface, of a recording-point having a curved cutting-edge and entering said record-surface in an oblique direction, substantially as set forth.

4. In a phonograph, the combination of a cylindrical phonogram-blank, a diaphragm, and a recording-point carried by the diaphragm having a curved cutting-edge, substantially as set forth.

5. In a phonograph, a recording-point having two or more cutting-edges, in combination with a holder holding such point normally in a fixed position, and in which such position may be changed to bring such cutting-edges successively into operating position, substantially as set forth.

6. In a phonograph, a recording-point having two or more arc-shaped cutting-edges, in combination with a holder holding said point normally in a fixed position, and in which the position of the point may be changed to bring such edges successively into operating position, substantially as set forth.

7. In a phonograph, a recording-point having a circular edge, in combination with a holder holding such point normally in a fixed position, and in which the position of the point may be changed, substantially as set forth.

8. In a phonograph, a recording-point having two or more cutting-edges, in combination with a holder in which the point may be turned to bring such cutting-edges successively into operating position, substantially as set forth.

9. In a phonograph, the combination of a recording or reproducing point having a shank or extension, and a sleeve for holding the same, substantially as set forth.

10. In a phonograph, the combination, with a holding-sleeve, of a recording or reproducing point having a shank, and an enlarged

portion meeting said sleeve when the shank is inserted therein, substantially as set forth.

11. In a phonograph, a reproducing-point whose bearing-surface is the surface of a portion of a sphere, substantially as set forth.

12. In a phonograph, a spherical reproducing-point, substantially as set forth.

13. A sound-record consisting of circular indentations or depressions having rounded sides and corresponding to the sound-waves, substantially as set forth.

14. A sound-record consisting of circular indentations or depressions having rounded sides and corresponding to the sound-waves, in combination with a diaphragm and reproducing-point whose bearing-surface is the surface of a portion of a sphere, substantially as set forth.

15. In a phonograph, a reproducing-point pivoted so as to have a lateral movement, in combination with a weight bearing thereon, substantially as set forth.

16. In a phonograph, a reproducing-point having a bearing-surface which is the surface of a portion of a sphere and pivoted so as to have a lateral movement, in combination with a weight bearing thereon, substantially as set forth.

17. In a phonograph, a reproducing-point having a bearing-surface which is the surface of a portion of a sphere and pivoted so as to have a lateral movement, substantially as set forth.

18. In a phonograph, a laterally-rocking spherical reproducing-point, in combination with a weight bearing thereon, substantially as set forth.

19. A sound-record consisting of circular indentations or depressions corresponding to sound-waves, in combination with a reproducing-point whose bearing-surface is the surface of a portion of a sphere, and which is pivoted so as to have a lateral movement, substantially as set forth.

20. In a phonograph, the combination of the reproducing-point, the lever carrying the same and connected with the diaphragm, the hinged plate, and the hinge-connection between said lever and said plate, substantially as set forth.

21. In a phonograph, the combination of the reproducing-point, the lever carrying the same and connected with the diaphragm and having a longitudinal slot, the hinged plate, the lugs on said plate, and the pin connecting said lugs and passing through said slot, substantially as set forth.

22. In a phonograph, a recording-point having a cylindrical head provided with a cutting-edge and a shank or extension, substantially as set forth.

23. In a phonograph, a recording-point having a cylindrical head with its end hollowed to form a circular cutting-edge, substantially as set forth.

24. In a phonograph, a recording-point hav-

- ing a cylindrical head with its end hollowed to form a circular cutting-edge and a shank or contracted extension, substantially as set forth.
- 5 25. In a phonograph, a reproducing-point having a head whose bearing-surface is a portion of the surface of a sphere, and a shank or contracted extension, substantially as set forth.
- 10 26. In a phonograph, a reproducing-point having a spherical head and a contracted shank, substantially as set forth.
- 15 27. In a phonograph, a reproducing-point having a spherical head, a contracted shank, and a flange on said shank, substantially as set forth.
- 20 28. In a phonograph, the combination, with a diaphragm, of a sleeve connected with said diaphragm so as to receive motion therefrom and a recording or reproducing point removably and rigidly held in said sleeve, substantially as set forth.
29. In a phonograph, the combination of a diaphragm, a lever connected therewith, a sleeve carried by said lever, and a recording or reproducing point removably held in said sleeve, substantially as set forth.
30. In a phonograph, the combination of a diaphragm, a lever connected therewith, a sleeve carried by said lever, and a recording or reproducing point having a head and a shank or contracted extension removably held in said sleeve, substantially as set forth.
31. In a phonograph, a recording or reproducing point in combination with a holding-sleeve and a cement, such as will be softened by heat, holding said point in said sleeve, substantially as set forth.
32. In a phonograph, the combination of a recording-point having a curved cutting-edge and a reproducing-point having a rounded bearing-surface, substantially as set forth.
- This specification signed and witnessed this 8th day of April, 1889.
- THOMAS A. EDISON.
- Witnesses:
WILLIAM PELZER,
D. H. DRISCOLL.