

(No Model.)

T. A. EDISON.  
TURNING-OFF DEVICE FOR PHONOGRAPHS.

No. 448,781.

Patented Mar. 24, 1891.

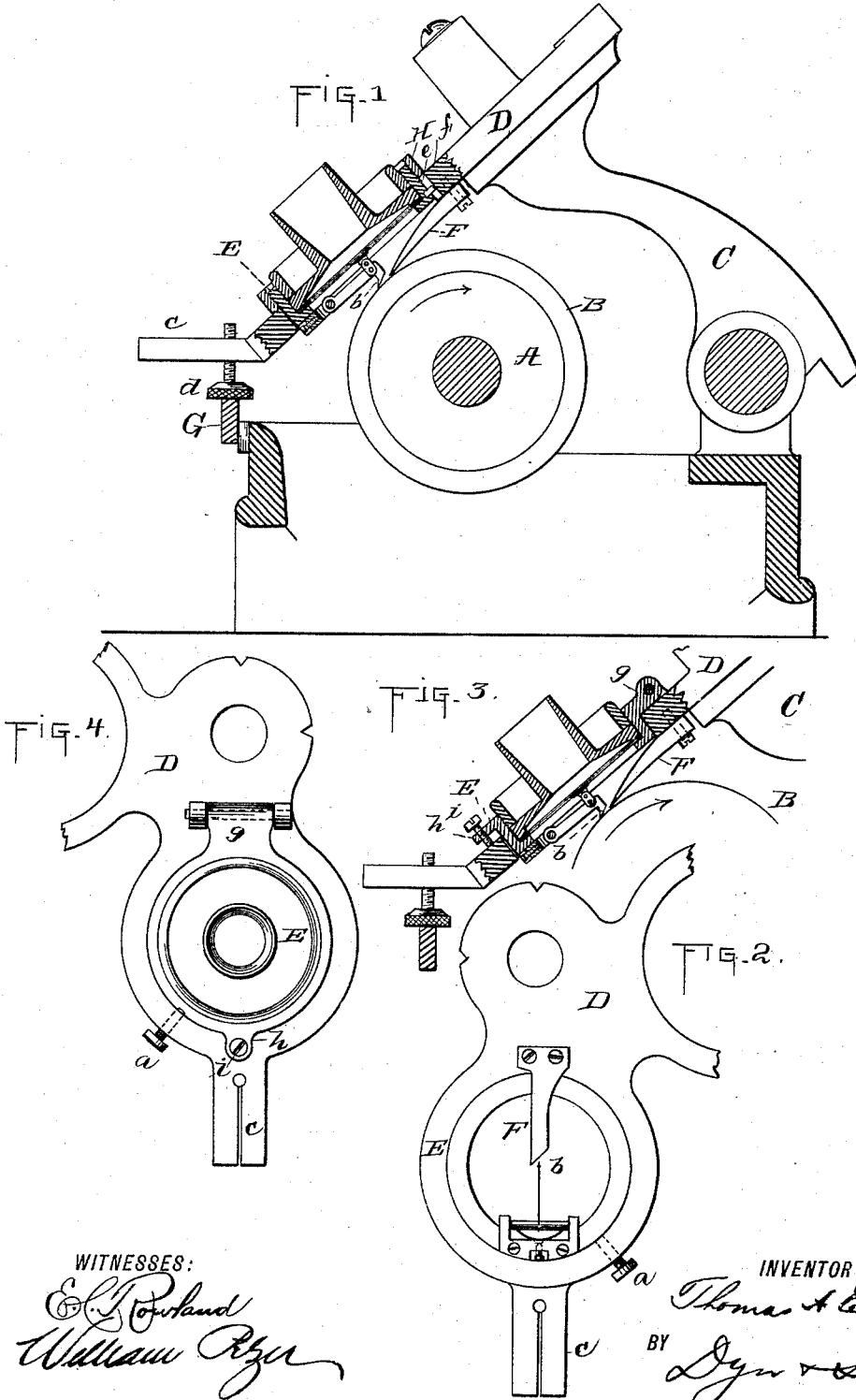

WITNESSES:  
*E. Rowland*  
*William Rizer*

INVENTOR  
*Thomas A. Edison*  
BY *Dyer & Seely*  
ATTORNEYS.

# UNITED STATES PATENT OFFICE.

THOMAS A. EDISON, OF LLEWELLYN PARK, NEW JERSEY.

## TURNING-OFF DEVICE FOR PHONOGRAPHS.

SPECIFICATION forming part of Letters Patent No. 448,781, dated March 24, 1891.

Application filed July 30, 1888. Serial No. 281,455. (No model.)

*To all whom it may concern:*

Be it known that I, THOMAS A. EDISON, a citizen of the United States, residing at Llewellyn Park, in the county of Essex, in the State of New Jersey, have invented a certain new and useful Improvement in Phonographs, (Case No. 794,) of which the following is a specification.

My phonograph is provided with a knife for turning off the surface of the phonogram-blank, so that the blank may be used for successive records, and so that the blank will be true for receiving the record on the particular machine. The knife acts with the recorder, the old record being removed and the new one being made at the same time. Heretofore such knife has been mounted on the rocking holding-arm of the machine, the knife being held by a lever pivoted upon the rocking holding-arm and provided with an adjusting-screw for raising and lowering the point of the knife. The position both of the recorder and the cutting-knife is simultaneously adjusted with reference to the recording-surface by means of an adjusting-screw bearing on a straight guide-rest, along which it travels as the rocking holding-arm is advanced by the feed-screw. As the cutting-knife has been heretofore employed its proper adjustment required considerable skill, since it not only had to be adjusted to properly cut the surface of the phonogram-blank, but also had to be adjusted with relation to the recording-point, so that the recording-point would at the same time track properly on the surface in rear of the cut of the knife, and this adjustment had to be such that the common adjustment of both these elements by the set-screw on the guide-rest could be made without disturbing the relation between the cutting-knife and the recording-point.

The object I have in view is to so construct the parts that a much simpler adjustment will be permitted, and a further object is to so mount the cutting-knife upon the machine that it will be moved laterally toward and away from the recording-surface with the recorder.

In carrying out my invention the cutting-knife is mounted rigidly and without an adjustment upon the machine, and the recorder itself is provided with an independent adjust-

ment toward and away from the recording-surface. This makes it possible to first manipulate the guide-rest adjustment until the knife cuts a proper shaving from the surface, and then to adjust the recorder independently of the spectacle-frame which carries it, while holding the speaking-tube to the ear, so that when the recording-point is properly tracking on the surface of the blank the operator will be made aware of the fact by the continuous and uniform scraping noise. This makes an exceedingly simple and perfect adjustment, and one which will permit the guide-rest adjustment to be afterward made, lowering the recording-point and the knife for subsequent records without changing their relation. In order to best fix the position of the knife and the recording-point against possible disturbances, I prefer to mount the knife directly upon the swinging spectacle-frame which carries the recorder. By this construction, also, the knife is moved laterally away from the record with the recorder.

In the accompanying drawings, forming a part hereof, Figure 1 is a sectional view of the phonograph, showing the knife in position for operation. Fig. 2 is a bottom view of a part of the spectacle-frame, showing the knife and the recorder. Fig. 3 is a view similar to Fig. 1, showing a different means for adjusting the recorder; and Fig. 4 is a top view of the spectacle-frame with the adjusting means of Fig. 3.

A is the turning phonogram-cylinder of my machine, carrying the phonogram-blank B. The advancing rocking holding-arm C has pivoted to its upper end the swinging spectacle-frame D, having two eyes, one of which carries the recorder and the other the reproducer. This frame is swung laterally to bring either of these instruments into operative relation with the surface of the phonogram-blank. The recorder and reproducer are instruments complete in themselves and separable from the machine, each being carried by an annular frame E, which is inserted in the eye of the spectacle-frame, and is secured therein by a set-screw *a*. The recording-point *b* projects beyond the ring-frame E, in order to indent the surface of the phonogram-blank. F is the knife or turning-off tool. It is preferably attached to the under side of the swing-

ing spectacle-frame D just above the eye holding the recorder. It is fastened rigidly in position to the spectacle-frame and projects toward the point of the recorder, which it approaches as closely as possible, and terminates in an oblique cutting-edge. The eye of the spectacle-frame carrying the recorder is provided with a finger *c*, through which passes a set-screw *d*, resting on the straight guide-rest G, along which it travels. By adjusting the screw *d* the cutting-knife and the recorder are simultaneously moved toward and away from the surface of the phonogram-blank. In order to secure the proper relative adjustment between the recording-point and the cutting-knife, I make the recorder independently adjustable in the eye of the spectacle-frame, so that independently of the guide-rest adjustment the recording-point can be adjusted toward and away from the surface of the blank. This adjustment of the recorder may be secured in various ways. Two means for securing the adjustment are illustrated by the drawings. In Fig. 1 a screw-ring II is shown, which embraces the edge of the annular frame E of the recorder and forms a shoulder for such frame, which rests upon the spectacle-frame. By adjusting the screw-ring II the depth to which the recorder enters the eye of the spectacle-frame can be varied and the recording-point moved toward or away from the recording-surface. A slot *e* and pin *f* may be employed to prevent the turning of the recorder when the adjusting-screw II is being turned.

In Figs. 3 and 4 the annular frame E of the recorder is shown as hinged upon the spectacle-frame, it having an upwardly-extending lug *g* resting between two lugs on the spectacle-frame and pivoted by a cross-pin which is removable. Opposite to the lug *g* the annular frame E of the recorder is provided with a lug *h*, through which an adjusting-screw *i* sets against the top of the spectacle-frame. It is evident that by adjusting the screw *i* the recorder will be adjusted more or less into or out of the eye of the spectacle-frame. With either of the adjustments already described the set-screw *a* is used to secure the recorder rigidly in position after the proper adjustment has been obtained.

In adjusting the parts the recorder may be first raised so as to clear the surface, and the screw *d* can then be adjusted to let the knife down upon the surface of the blank until it is seen that the knife is cutting a proper shaving to remove the old record. The speaking-tube is then connected with the recorder, and is held to the ear of the operator while the recorder is adjusted toward the surface by turning the screw-ring II or the set-screw *i*. When the operator ascertains that the recording-point is tracking properly by hear-

ing the continuous and uniform sound of the recorder in cutting the surface, then he knows that the proper adjustment has been secured. He then binds the recorder in place by means of the set-screw *a*. The adjustment being once secured, the relation between the recording-point and the cutting-knife will be maintained for subsequent manipulations of the guide-rest adjustment, so that the screw *d* can be adjusted to lower the recording-point and the cutting-knife simultaneously. It is only when the recorder is removed for any particular purpose and is again placed in position that the parts have to be readjusted. It will be seen that the cutting-knife, being mounted directly upon the spectacle-frame, swings with such spectacle-frame, and is brought into and out of operation with the recorder by the lateral swinging of the spectacle-frame.

What I claim is—

1. In a phonograph, the combination of a cutting-knife mounted rigidly and without an adjustment on the machine and a recorder adjustable with relation to said cutting-knife, substantially as set forth.

2. In a phonograph, the combination, with the rocking holding-arm, the guide-rest, and the guide-rest adjustment, of a recorder carried by a frame supported by the rocking holding-arm and the guide-rest, said frame having an adjustment toward and away from the recording-surface, and said recorder having an adjustment toward and away from the recording-surface additional to the adjustment of said frame, substantially as set forth.

3. In a phonograph, the combination, with the rocking holding-arm, the guide-rest, and the guide-rest adjustment, of a cutting-knife and a recorder supported from said rocking holding-arm and said guide-rest, said cutting-knife mounted rigidly and without adjustment on the machine, and said recorder being independently adjustable with relation to said cutting-knife, substantially as set forth.

4. In a phonograph, the combination, with the swinging spectacle-frame carrying the recorder, of the cutting-knife mounted upon such swinging spectacle-frame, substantially as set forth.

5. In a phonograph, the combination, with the rocking holding-arm, the swinging spectacle-frame, the guide-rest, and the guide-rest adjustment, of the cutting-knife secured to such swinging spectacle-frame and having a fixed position thereon and the recorder adjustably held by said swinging spectacle-frame, substantially as set forth.

This specification signed and witnessed this 16th day of July, 1888.

THOS. A. EDISON.

Witnesses:

WILLIAM PELZER,  
A. W. KIDDLE.