

(No Model.)

2 Sheets—Sheet 1.

T. A. EDISON.
ELECTRIC LOCOMOTIVE.

No. 475,492.

Patented May 24, 1892.

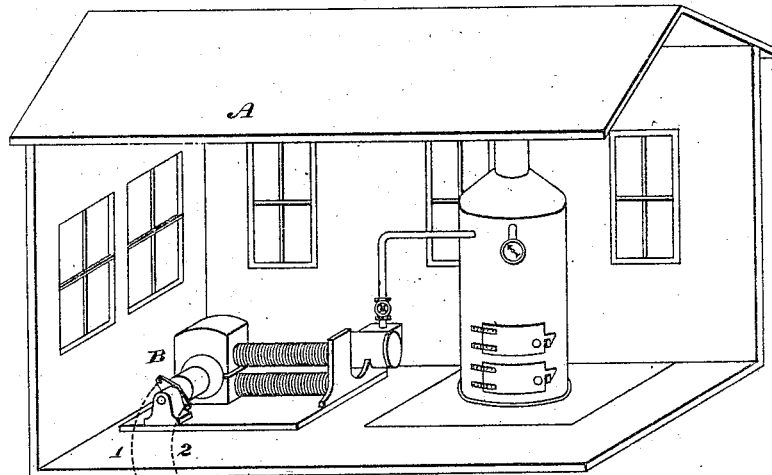
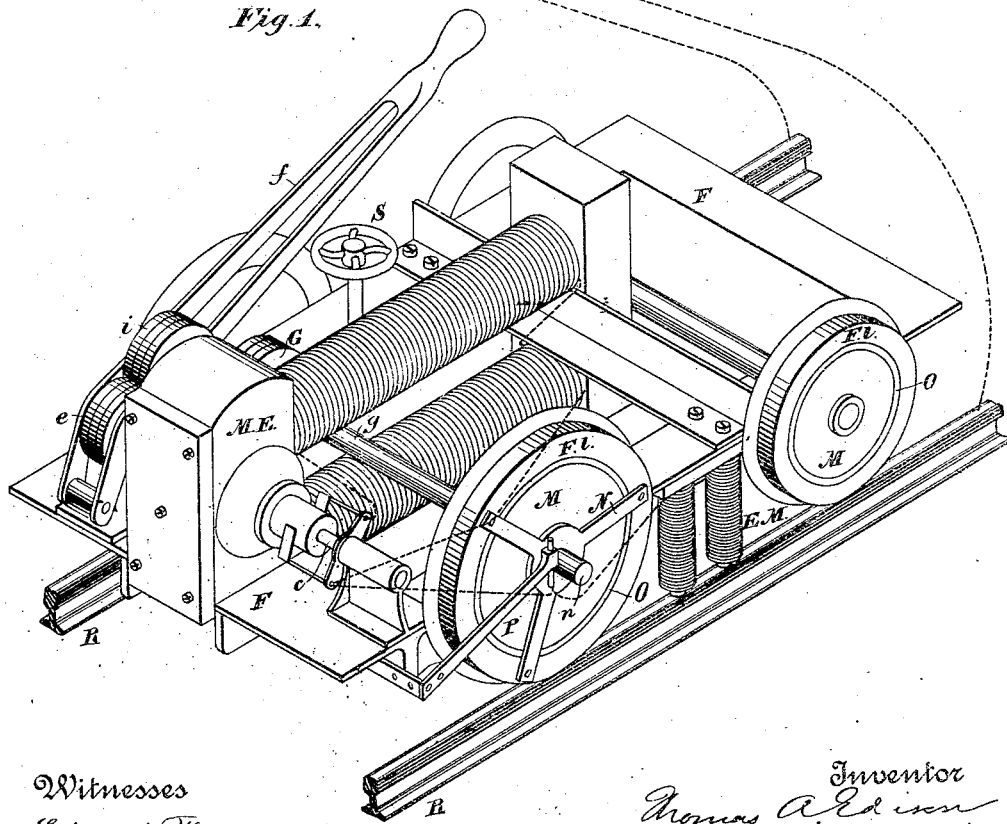

Fig. 1.



Witnesses
Edward Thorpe.
William Cicels

Inventor
Thomas A. Edison
By his Attorney Wm. P. Vansize

(No Model.)

T. A. EDISON.
ELECTRIC LOCOMOTIVE.

2 Sheets—Sheet 2.

No. 475,492.

Patented May 24, 1892.

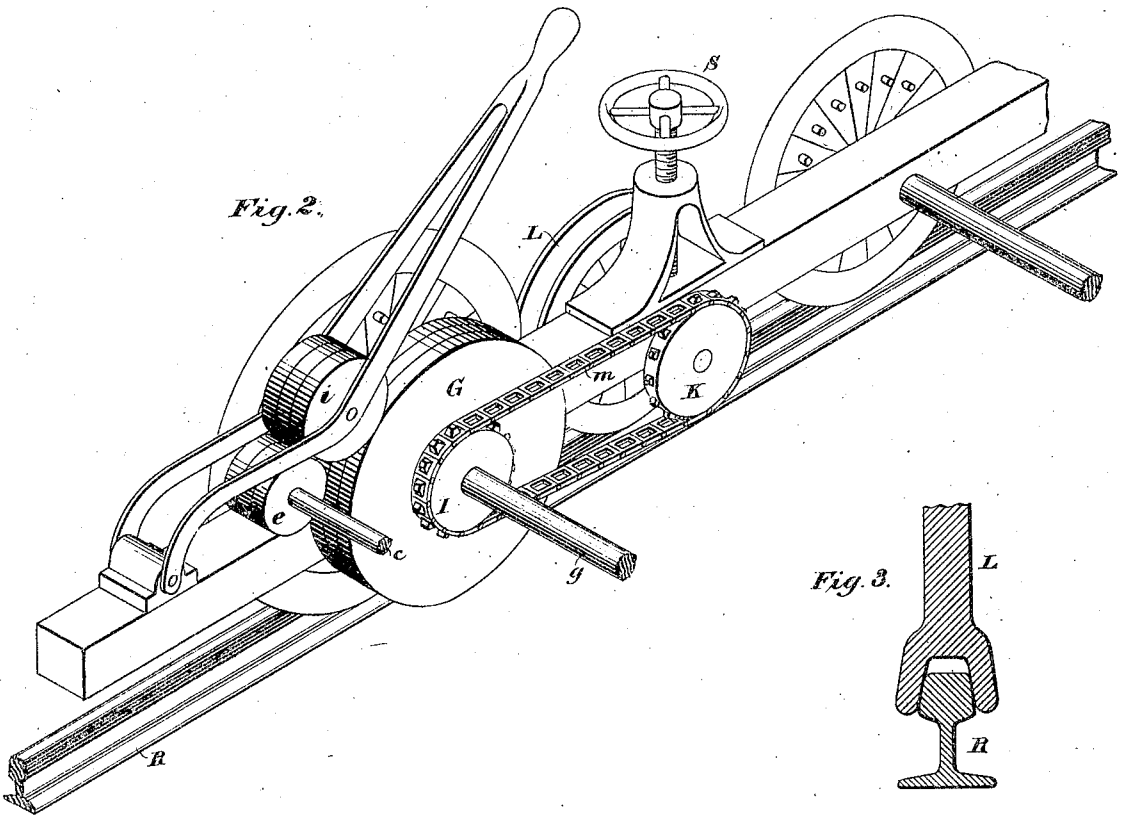

Fig. 2.

Fig. 3.

Witnesses
Edward Thorpe.
William Dickie.

Inventor
Thomas A. Edison
By his Attorney *Wm. O. Wainwright*

UNITED STATES PATENT OFFICE.

THOMAS A. EDISON, OF LLEWELLYN PARK, NEW JERSEY, ASSIGNOR TO THE EDISON ELECTRIC LIGHT COMPANY, OF NEW YORK, N. Y.

ELECTRIC LOCOMOTIVE.

SPECIFICATION forming part of Letters Patent No. 475,492, dated May 24, 1892.

Original application filed June 3, 1880, Serial No. 11,243. Divided and application filed May 20, 1882, Serial No. 61,955. Again divided and this application filed June 9, 1891, Serial No. 395,702. (No model.) Patented in England September 25, 1880, No. 3,894; in Canada March 31, 1881, No. 12,568; in India May 3, 1881, No. 341; in Victoria May 12, 1881, No. 3,012; in France May 27, 1881, No. 141,752; in New South Wales June 25, 1881, No. 948; in Queensland June 30, 1881, No. 21/299, and in New Zealand August 2, 1881, No. 542.

To all whom it may concern:

Be it known that I, THOMAS A. EDISON, of Llewellyn Park, in the county of Essex and State of New Jersey, have invented a new and useful Improvement in Electro-Magnetic Railway Systems, (for which I have obtained Letters Patent in Great Britain, No. 3,894, dated September 25, 1880; in Canada, No. 12,568, dated March 31, 1881; in India, No. 341, dated May 3, 1881; in Victoria, No. 3,012, dated May 12, 1881; in France, No. 141,752, dated May 27, 1881; in New South Wales, No. 948, dated June 25, 1881; in Queensland, No. 21/299, dated June 30, 1881, and in New Zealand, No. 542, dated August 2, 1881;) and I do hereby declare that the following is a full and exact description of the same, reference being had to the accompanying drawings, and to the letters of reference marked thereon.

The object of this invention is to furnish an economical system of electro-magnetic railways or tramways which, while useful in any locality, shall be particularly adapted to regions where the traffic is too light for ordinary steam-railways or where the main bulk of the traffic is limited to certain seasons or where the difficulties or expense of grading render ordinary steam-roads impracticable.

To this end the invention consists in a complete electro-magnetic railway system embracing the generation, distribution, and utilization of electric currents as a motive power and in the novel devices and combination of devices therefor, as more particularly described and claimed.

In carrying my invention into effect the rails of the track are electrically connected, so that each line of rails forms a part of the circuit. For the traveling motor or locomotive an electro-magnetic engine is mounted upon a suitable frame supported upon the axles of the driving and other wheels. In order that the circuit from one line of rails to the other be not directly through the wheels and axles, but be through the motor, each car is, so to speak, electrically cut in two by the interposition of insulating material somewhere in its structure, the poles of the motor

being connected one to each division. A preferable method is to form the hub and flange of a wheel of separate metallic parts, uniting them by bolting each to a wooden web, which insulates the two, whereby the body of the car and the axles are insulated from the track. Contact-springs bear against the flanges or, preferably, against hubs secured thereto by cross-bars or spiders whose outer ends are bolted to the flanges. These contacts are connected to the brushes of the motor, one to each, respectively.

Provision is made to dispense with the necessity of much grading, enabling the engine to ascend ordinarily-impracticable grades, as follows: Upon one or both sides of the engine-car a wheel, having a grooved face adapted to clasp the head of the rail, is mounted in a bearing so combined with a screw or other lifting device that it may be depressed into or elevated from contact with the rail. Upon its axle is fixed a rag or sprocket wheel. Upon the main driving-axle is mounted a friction-wheel having attached to it a rag or sprocket pinion. To this wheel motion is communicated from a friction-wheel on the motor-shaft through an intermediate wheel mounted in a swinging frame, as before described.

A sprocket-chain connects the sprocket-wheel on the axle of the grooved wheel and the sprocket-pinion. Under ordinary circumstances this grooved wheel is not in contact with the track. When necessary, the grooved wheel is depressed and grasping and biting upon the rail-head pulls the load without slipping. By this arrangement there is furnished an economical and reliable system in any locality or over any grades where ordinary wagon traffic may be carried on.

In the accompanying drawings I show more in detail how this invention may be carried into effect. It is to be remembered, however, that these details may be varied or equivalents used, and that therefore I do not limit myself generally to the precise details illustrated.

Figure 1 is a perspective view of an engine-car. Fig. 2 is a perspective of the rail-grip-

ping device for ascending grades, and Fig. 3 is a section of a grooved wheel and rail.

B is a dynamo-electric generator connected in circuit with the track-rails R.

5 F is any suitable frame-work suspended from the main driving-axle and placed upon the other axle.

The wheels used under the engine-car and all other cars are constructed as shown. The flange F' and the hub M are made separately and connected by a wooden web O, to which they are bolted, the wheel then consisting of a metallic hub, a metallic flange, and an intervening wooden or insulating web. By this means the axle and body of the car are insulated from the flanges and track and the current cannot pass therethrough from one rail to the other. On the engine-car a spider or frame N is secured to the flange F', so as to be in electrical contact therewith, but not touching or forming contact with the hub M. Upon the center of N is a boss or spindle n, on which bears a contact-brush held by arm P. The current then passes from one line of rails through one flange F', frame N, boss or spindle n, contact-brush P to the electric engine, thence by the other arm P, spindle, frame, and flange to the other line of rails.

Motion is communicated to the main driving-axle g as follows. Upon axle g is a friction-wheel G. Upon the shaft c of the magnetic engine is a friction-pulley e, the pulleys e and G not being in contact. In a swinging frame f, pivoted at h, is mounted a friction-pulley i. The frame f, being depressed, bears upon e and G, and communicates motion from e to G, the percentage transferred being proportioned to the frictional contact of i upon e and G.

40 L is a grooved wheel in a vertically-adjustable bearing moved by the screw and hand-wheel S. The groove in L is shown in cross-section in Fig. 3, and is shaped to grip both sides of the head of the rail. Upon the shaft of wheel L is a sprocket-wheel K. Upon the main axle is a sprocket-wheel I. Both sprocket-wheels are mechanically connected by sprocket-chain m. The current flowing through the electric engine produces rotation of the armature-shaft, which is communicated to the axle g through the friction-wheels e, i, and G. When a grade is reached, or when any condition of the track is encountered which causes the car-wheels to slip, the screw S is op-

erated to depress grooved wheel L upon the rail R, motion of rotation being imparted to said wheel through wheels I and K by chain m. The grooved wheel L grips, grasps, or bites into the edges of the rail-head to such an extent that slipping is avoided and the car is moved steadily and vigorously.

I do not herein claim in an electro-magnetic railroad-engine the combination, with the electro-motor mounted thereon and the driving-wheels thereof, of means for connecting or disconnecting the two at will, whereby the engine may be stopped by withdrawing the power from the driving-wheels without stoppage of the motor, as that is claimed in another application, Serial No. 395,700, filed by me.

Any patentable subject-matter herein shown or described but not claimed forms the subject-matter of my concurrently-pending applications, Serial No. 11,243, filed June 3, 1880, and Serial No. 61,955, filed May 20, 1882, or of one of the divisions thereof, serially numbered 395,700, 395,701, 395,703, 395,704, 395,705, filed June 9, 1891.

What I claim, and desire to secure by Letters Patent, is—

1. The combination of a wheeled vehicle, an electric motor located thereon mechanically connected with a wheel or axle thereof, a source of electricity, a circuit including said source of electricity and motor, a track composed of rails upon which said vehicle travels, and a supplemental grooved traction-wheel upon said vehicle rotated by the same source of power as the motor, adapted to grasp or grip the track, substantially as described.

2. The combination of a wheeled vehicle, an electric motor located thereon mechanically connected with a wheel or axle thereof, a source of electricity, a circuit including the source of electricity and motor, a track composed of rails upon which said vehicle travels, a supplemental traction-wheel upon said vehicle rotated by the same source of power as the motor, and means for mechanically connecting and disconnecting said wheel with respect to the track, whereby said wheel may be used as necessity requires, substantially as described.

THOMAS A. EDISON.

Witnesses:

THOMAS MAGUIRE,
JOHN F. RANDOLPH.