

(No Model.)

T. A. EDISON.
PHONOGRAM BLANK.

No. 488,191.

Patented Dec. 20, 1892.

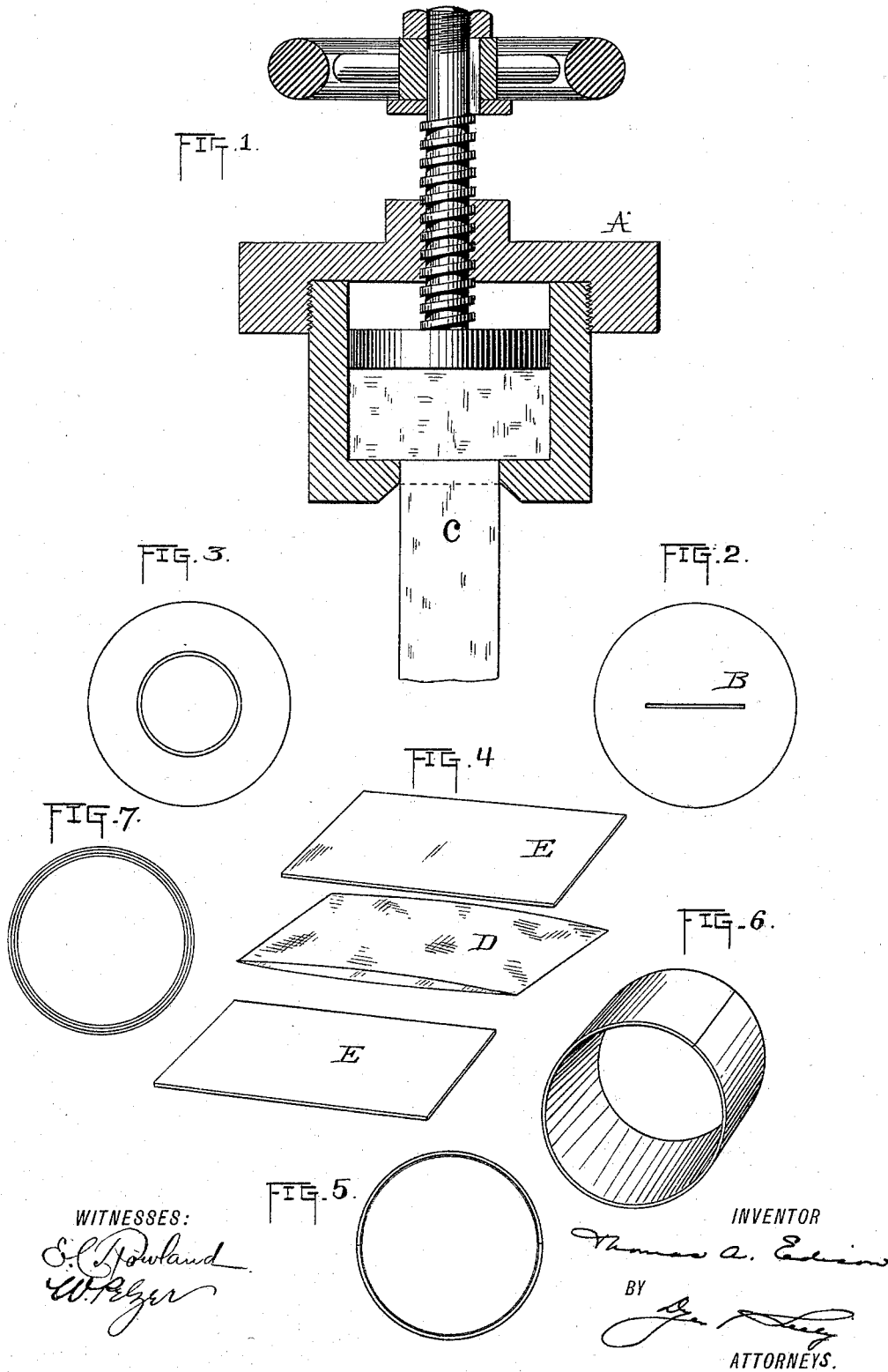

UNITED STATES PATENT OFFICE.

THOMAS A. EDISON, OF LLEWELLYN PARK, NEW JERSEY.

PHONOGRAM-BLANK.

SPECIFICATION forming part of Letters Patent No. 488,191, dated December 20, 1892.

Application filed January 19, 1889. Serial No. 296,876. (No model.)

To all whom it may concern:

Be it known that I, THOMAS A. EDISON, a citizen of the United States, residing at Llewellyn Park, in the county of Essex and State of New Jersey, have invented a certain new and useful Improvement in Phonogram-Blanks, (Case No. 812,) of which the following is a specification.

The object of this invention is to provide phonogram blanks or surfaces for receiving sound records in the phonograph, which shall be of a convenient and simple form and can be cheaply and readily manufactured, and which will be adapted to be conveniently packed in boxes and inclosed in envelopes for transmission by mail.

The main feature of the invention consists in the use of thin flexible sheets of wax or wax like material, which sheets either by themselves or combined with backings of other suitable material, are used as the recording mediums in phonographs. I may form such sheets of plastic flexible material, by rolling or pressing such material into sheets, but I prefer to produce them by forcing the material through an aperture of the desired form in a press. The sheets thus formed may be used in a variety of ways. Such sheets may themselves form flat recording surfaces for the phonograph, or they may be attached to backings of paper or similar flexible material and used as flat recording surfaces, or they may be formed into cylinders, either with or without an internal backing of paper or like material, or they may be placed upon rigid cylinders and used in the phonograph, or used in various other ways.

There are many compounds of wax or wax like material which may be employed for the purposes of my invention. What I prefer to use is a mixture of asphalt with Japan wax or pitches made from the distillation of fatty oils or combinations of fatty acids, any of which materials are equivalents of wax for the purposes of this invention. The proportions of the different substances will vary as the conditions differ and as sheets of different degrees of flexibility are required. Beginning with the asphalt alone, which is brittle even in thin sheets, the flexibility may be

brought to any desired degree by adding more or less of the Japan wax or equivalent flexible substance.

My invention is illustrated in the accompanying drawings:

Figure 1 illustrates the use of the squirting press for forming the thin sheets. Figs. 2 and 3 are bottom views of different forms of the press; Fig. 4 shows the preferred method of placing such thin sheets upon a paper backing; Fig. 5 illustrates a cylinder thus formed; Fig. 6, a cylinder formed from the plastic sheet alone; and Fig. 7 shows a cylinder formed of a number of plastic sheets which are intended to be torn off as they are used.

A quantity of the material, such as above described, is placed in the press A in the bottom of which is usually a slot or elongated aperture B, (Fig. 2.) The material is raised to such temperature as will insure its easy passage through the aperture, and the pressure is then applied, and the material forced in the form of a thin sheet C through the aperture, as illustrated in Fig. 1. I prefer to allow it to pass directly into water, so as to set it immediately, and prevent distortion while it is in a heated condition. After it is dry, it may be coated with fine powder, such as talc or kaolin, to prevent the surface from adhering to other objects, and the strip which has come from the press is then cut up into sheets of the required size. These sheets may, as above stated, be used in many different ways. The sheet may be bent around a forming cylinder and the ends overlapped and pressed together, the surplus material being removed by a cutting or scraping tool, or preferably the ends are made to meet and are joined together by the application of a heated wire or by the addition of a small amount of the softened material along the joint. By this means cylinders like that shown in Fig. 6 are formed. Instead of this however, a sheet of thin paper may be cut to the proper size and formed into a cylinder with its edges joined, and this cylinder is then collapsed into a flat double sheet as illustrated in Fig. 4, the collapsed cylinder being shown at D. The double sheet D is placed between two sheets E E of the flexible wax like material and the whole is submitted

55

60

65

70

75

80

85

90

95

100

to pressure. The backs of the sheets E, or the sheet D being previously moistened with a solvent of the flexible material, such as benzol, the sheets E are thus made to adhere
 5 firmly to the sheet D, whereby a collapsed phonogram blank is formed, which can be drawn out into a cylinder and placed upon the cylinder of the phonograph, or upon a false shell placed thereon. A cylinder drawn
 10 out into form for use is shown in Fig. 5.

Instead of a backing of paper, the thin flexible sheets formed into cylinders like Fig. 6 or used in sheet form, as flat recording surfaces, may be covered with a varnish, such as a solution of a suitable gum, like gum balata, in
 15 a solvent such as bi-sulphide of carbon. A number of sheets of this character can be formed into a composite cylinder as shown in Fig. 7, the different layers, one of which is affected at a time by the phonograph recorder,
 20 being torn off as they are used.

The squirting press may have an annular aperture as shown in Fig. 3, whereby the material may be forced out in the form of cylinders
 25 instead of in sheets.

What I claim is:

1. A collapsible phonogram blank consist-

ing of a cylinder of flexible material with separable sheets of flexible wax or wax like material placed thereon, substantially as set forth. 30

2. A composite phonogram blank, consisting of two or more separately removable layers of recording material, each layer being of such thickness that a record impressed on one
 35 layer will not be transmitted to a succeeding layer substantially as set forth.

3. A composite phonogram blank, consisting of a cylinder of two or more separately removable layers of recording material, each
 40 layer being of such thickness that a record impressed on one layer will not be transmitted to a succeeding layer substantially as set forth.

4. A phonogram blank having in combination super-imposed separable layers of flexible wax or wax like material, substantially as set forth. 45

This specification signed and witnessed this 10th day of January, 1889.

THOMAS A. EDISON.

Witnesses:

H. W. SEELY,
 W. PELZER.