

(No Model.)

T. A. EDISON.  
MIXER.

2 Sheets—Sheet 1.

No. 605,668.

Patented June 14, 1898.

Fig. 1.

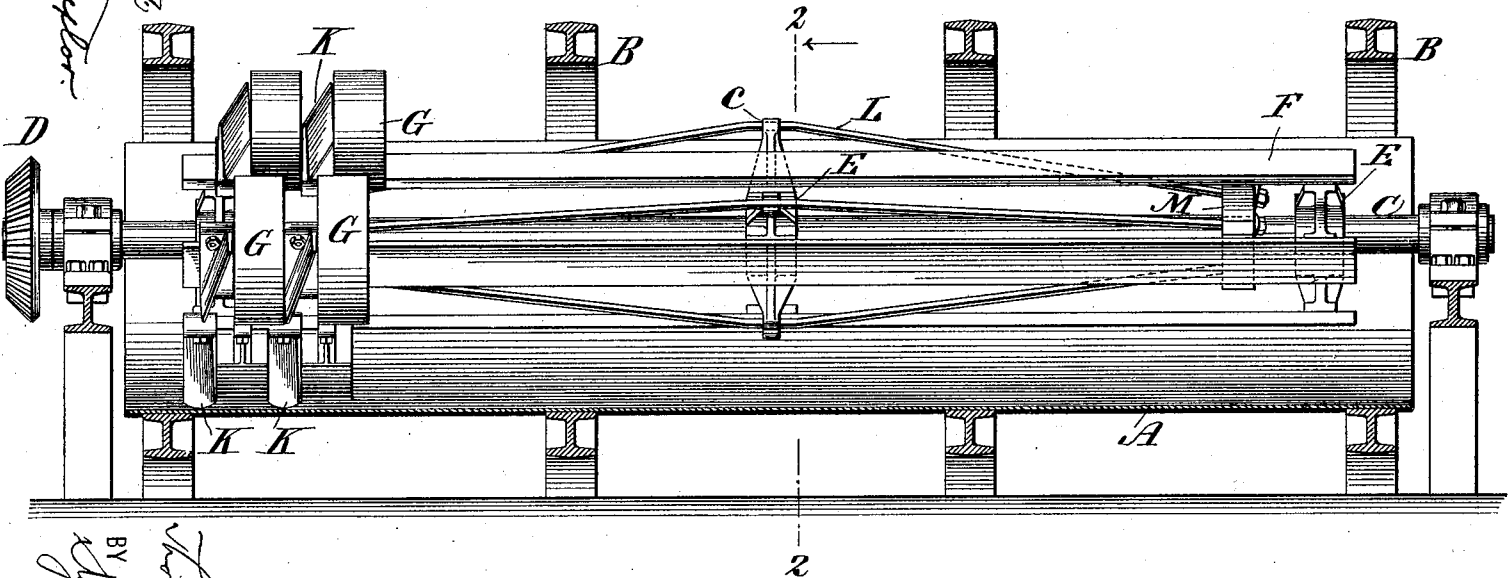

WITNESSES:

*A. K. Maynard*  
*Geo. P. Sawyer*

INVENTOR  
*Thomas A. Edison*  
BY  
*Wm. S. Burdick*  
ATTORNEYS

(No Model.)

T. A. EDISON.  
MIXER.

2. Sheets—Sheet 2.

No. 605,668.

Patented June 14, 1898.

Fig. 3

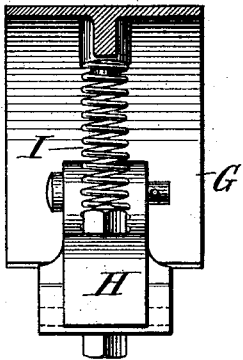

Fig. 4,

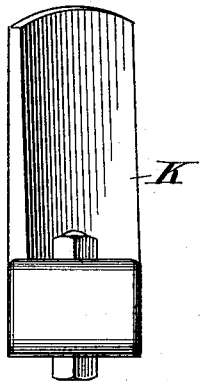
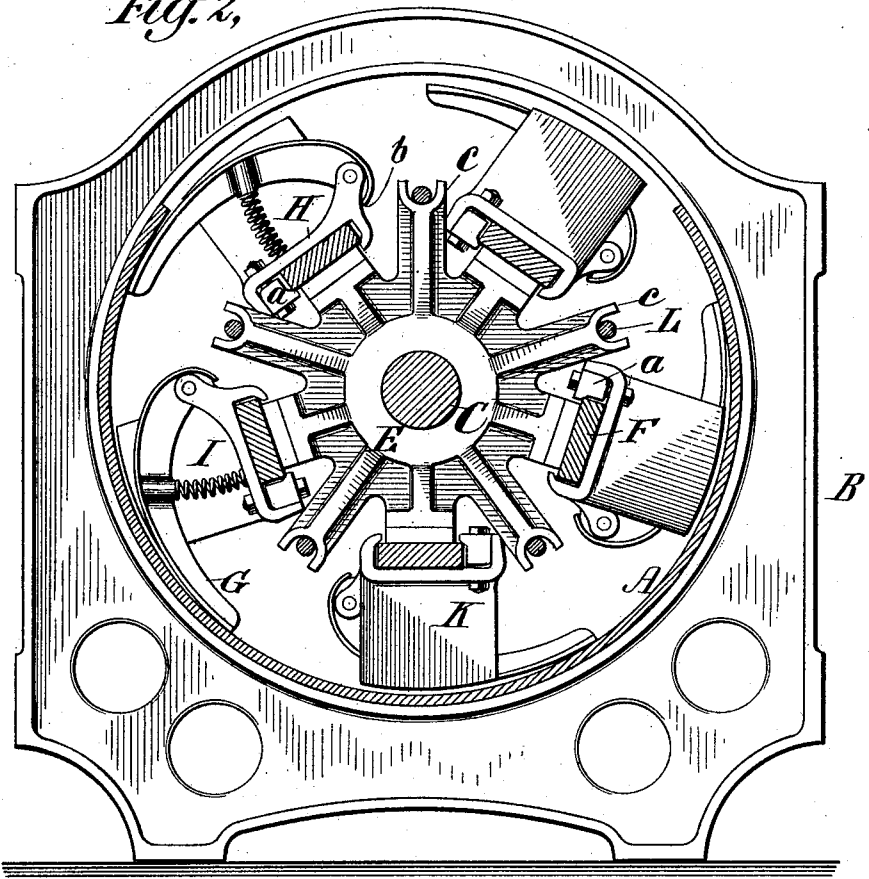

Fig. 2,



WITNESSES:

*W. H. Hayward*  
*Geo. D. Sawyer*

INVENTOR  
*Thomas Edison*  
 BY  
*Wm. S. Sweet*  
 ATTORNEYS

# UNITED STATES PATENT OFFICE.

THOMAS A. EDISON, OF LLEWELLYN PARK, NEW JERSEY.

## MIXER.

SPECIFICATION forming part of Letters Patent No. 605,668, dated June 14, 1898.

Application filed June 29, 1897. Serial No. 642,813. (No model.)

*To all whom it may concern:*

Be it known that I, THOMAS A. EDISON, a citizen of the United States, residing at Llewellyn Park, in the county of Essex and State of New Jersey, have invented a certain new and useful Improvement in Mixers, (Case No. 979,) of which the following is a specification.

I have found great difficulty in securing a suitable apparatus for mixing concentrated pulverized iron ore with a binding material preparatory to the molding of the material into briquets. In order to use a minimum quantity of binding material, it is necessary that an exceedingly thorough mixture should be obtained. The object of my invention is to produce an apparatus suitable for this purpose as well as for mixing materials of a similar nature.

In the accompanying drawings, forming a part hereof, Figure 1 is a longitudinal section of the mixing-trough, showing in elevation two sets of the mixing devices. Fig. 2 is a cross-section on line 2 2 of Fig. 1. Fig. 3 is a sectional view of one of the spreaders, and Fig. 4 is a view of one of the plows.

The mixing-trough A is a horizontally-placed sheet-metal circular trough open at the top and at both ends. It is supported at the ends and at one or more intermediate points by cast-iron inclosing frames B. Centrally through the trough passes a shaft C, supported at its ends, outside of the trough, in suitable bearings. This shaft is driven at one end by a gear-wheel D, connected suitably with a source of power. At the ends and center of the shaft are secured cast-iron spiders E, upon which are securely bolted a number of longitudinal bars F, running parallel with the shaft. Five of these bars are shown, but a greater or less number may be employed. Bolted to the bars F throughout their length are a succession of mixing-spreaders and plows. The spreaders are curved shoes G, having curved flat faces which rub on the inner surface of the trough A. These shoes are pivoted to blocks H, which are clamped by key-blocks a to the bars F. The spreaders are thrown outwardly by springs I, their outward movement being limited by the striking of the curved end b of the shoe against the block H, so that when the shoe leaves the

surface of the trough its outward movement beyond the surface will be limited. The inward movement of the spreaders is opposed by the springs. The inward movement permitted is so great with reference to the thickness of the material operated on that the springs are never wholly compressed. Hence a definite spring-pressure is obtained, and danger of breakage is avoided. The plows are flat plates, having curved ends which do not come in actual contact with the trough, these plates being set at an angle, as shown. The plows K are secured to the bars F by key-blocks b. The plows and spreaders are placed close together side by side throughout the length of the bars F, the plows on one bar being set so that each will throw a ridge of material in the path of a spreader on the next succeeding bar.

While only two sets of spreaders and plows are shown in Fig. 1, it will be understood that the entire length of the bars F is taken up by similar spreaders and plows.

The materials to be mixed being fed into the trough at one end and the shaft rotated the mixture will be gradually advanced toward the other end of the trough by the action of the plows. Each plow throws the mixture into a ridge, and the succeeding spreader spreads out the ridge and draws or kneads the mixture, producing an intimate mixture of the materials and preventing the balling of the mixture. The rate of progression of the mixture through the trough is slow, and it is subjected many times to the action of the plows and spreaders. Indeed the material may be passed through a series of these mixers in succession.

To prevent the springing of the shaft C under the great strain to which it is subjected, I provide a number of truss-rods L. These are bolted to blocks M, secured to the shaft C near its ends, but within the outside spiders E. The truss-rods L pass outwardly from the blocks M over arms c, projecting radially from the middle spider E.

What I claim is—

1. In a mixer, the combination of a trough, a shaft mounted longitudinally within the trough, a plurality of longitudinal bars supported by said shaft parallel therewith and

mixing devices carried by said bars and working within the trough, substantially as set forth.

2. In a mixer, the combination of a trough, a shaft mounted within said trough, a plurality of longitudinal bars supported by the shaft parallel therewith and a plurality of mixing devices removably secured to said bars and adjustable longitudinally thereon, substantially as set forth.

3. In a mixer, the combination with the trough and the shaft, of longitudinal bars supported by the shaft parallel therewith, and plows and spreaders carried by the bars, substantially as set forth.

4. In a mixer the combination of a trough, a shaft mounted longitudinally therein, lon-

gitudinal bars supported by the shaft parallel therewith and plows and spreaders removably secured to said longitudinal bars and alternately arranged thereon, substantially as and for the purpose set forth.

5. In a mixer, the combination with the trough, of the shaft, spiders on the shaft carrying longitudinal bars, plows and spreaders supported by these bars, and truss-rods lengthwise of the shaft to stiffen the shaft, substantially as set forth.

This specification signed and witnessed this 10th day of June, 1897.

THOMAS A. EDISON.

Witnesses:

RICHARD N. DYER,  
W. PELZER.