

No. 703,562.

T. A. EDISON.

Patented July 1, 1902.

APPARATUS FOR BRICKING PULVERIZED MATERIAL.

(No Model.)

(Application filed May 23, 1898.)

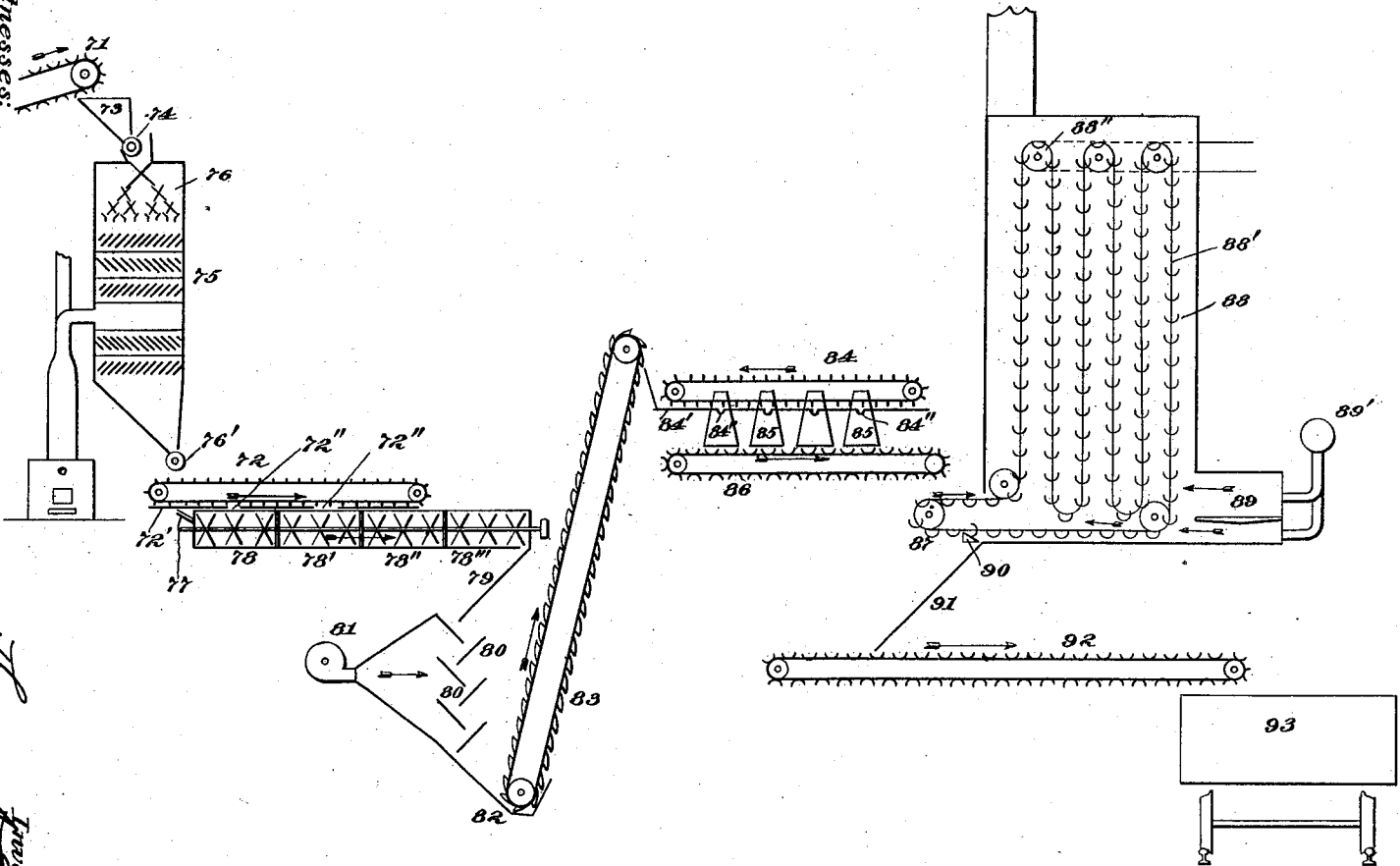

Witnesses:  
*Wm. A. ...*  
*Geo. A. ...*

Inventor:  
*Thomas A. Edison*  
*By ...*  
*Atty.*

# UNITED STATES PATENT OFFICE.

THOMAS A. EDISON, OF LLEWELLYN PARK, NEW JERSEY.

## APPARATUS FOR BRICKING PULVERIZED MATERIAL.

SPECIFICATION forming part of Letters Patent No. 703,562, dated July 1, 1902.

Application filed May 23, 1898. Serial No. 681,479. (No model.)

*To all whom it may concern:*

Be it known that I, THOMAS A. EDISON, a citizen of the United States, residing at Llewellyn Park, in the county of Essex and State of New Jersey, have invented a certain new and useful Improvement in Apparatus for Bricking Pulverized Material, (Case No. 997,) of which the following is a specification.

My present invention relates to improved apparatus for bricking iron ore, coal, or other material in pulverized form.

The objects of the invention are to provide an apparatus for this purpose by means of which the pulverized material will be placed in proper condition for effective bricking and after being molded into briquets of the proper form will be baked, so as to attain the desired solidity.

In the bricking of material I find that a suitable binding agent is necessary for obtaining briquets of the desired solidity, and such a binding agent should be of a highly-viscid character, whereby relatively small proportions thereof may be used. I have found that a binding agent consisting of rosin and petroleum is very advantageous, particularly when used in the bricking of magnetite iron ores, with which I have experimented and which comprise, essentially, ferric and ferrous oxides, for the reason that since the latter oxide is the base the chemical combination with rosin results in the formation of resinate of iron. With a binder of this character I have obtained briquets which maintain their shape even when subjected to the intense heat of the blast-furnace, owing to the fact that resinate of iron does not melt up to the point of carbonization. I find that in order that the mixing of the binding agent with the pulverized material may be carried on with the expenditure of the minimum power and with the employment of the minimum proportion of a binding material it is necessary that the pulverized ore or other substance should be kept in a heated state. When this is done, a very much more thorough admixture of the binding agent with the ore or other material is obtained and a better and more coherent briquet is produced. My apparatus therefore consists, preferably, in the first place, of a suitable heating device by which enormous quantities of ore or other pulverized material

may be brought to the required temperature. The preferred form of heating device which I use is one constructed on the same lines as my improved drier, which I describe and claim in an application for Letters Patent filed on even date herewith. It comprises, essentially, a vertical chamber having a large number of inclined baffle-plates therein, by means of which the material falling through the chamber will be caused to partake of zigzag paths, a distributor being employed at the top of the chamber for subdividing the material throughout the entire area thereof. In order that the ore or other pulverized substance may be heated, hot air and products of combustion are directed through the drying-chamber, so as not only to heat the inclined baffle-plates thereof, but to also come into direct contact with the falling streams of material. The material having been heated to the proper point is introduced into a mixing apparatus operated by power and is intimately admixed with the binding agent, which, as stated, is composed, preferably, of petroleum and rosin. This binding agent is obtained by first melting ordinary rosin and adding thereto crude petroleum or other liquid hydrocarbon in the proportion of about one hundred parts, by weight, of rosin and thirty-five parts, by weight, of petroleum. These proportions, however, vary according to the climate and season, less petroleum being required in summer than in winter in order to procure the same viscosity of the binding agent when cold. About fifty pounds of this mixture will serve as a binder for a ton of finely-pulverized iron ore, the latter being reduced to sufficient fineness to pass through a screen of fifty meshes to the linear inch. The mixing device which I preferably employ is one such as I have described and claimed in my application for Letters Patent filed June 29, 1897, and numbered serially 642,813, said mixer comprising a series of semicylindrical troughs set end to end, with a horizontal shaft rotating concentrically therein. The said shaft carries a number of spring-pressed plows and spreaders, the former being inclined, so as to serve to advance the material slowly through the trough and form it into ridges in line with the spreaders, which serve to press down such ridges with a trowel-like action and to thereby inti-

mately mix the binder with the pulverized material. I find that the best results in practice are obtained when the material from the heating device is distributed over a plurality  
 5 of (preferably four) mixing-troughs and when the entire bulk of the binding substance is introduced into the first of said troughs. In this way a relatively large proportion of binding substance will be intimately mixed with  
 10 the material; but this proportion will become relatively less until the desired amount is secured as the material advances through the mixing-troughs and fresh material is added to the same. After the binding substance  
 15 has been admixed with the material and if the latter is still heated it cannot be effectively bricked, owing to its high viscosity. I therefore prefer to allow the mixture to become cold, which may be effected by exposing  
 20 it to the air for a sufficient time; but preferably this cooling is secured mechanically. My apparatus therefore comprises, in its preferred form, a mechanical cooling device, to which the mixture will be directed  
 25 after the same has left the mixers. This cooling device may and preferably does comprise a plurality of inclined screen-sections or plates, over which the material will pass, being simultaneously subjected to the effect of  
 30 air-blasts from a fan or blower. After being cooled the mixture of pulverized material and the binding agent is directed to suitable bricking-machines, by which it will be formed into briquets or bricks of the desired size  
 35 and shape.

The bricking-machines which I prefer to employ are those which are described and claimed in my application filed on even date herewith. They comprise, essentially, a rotatable mold-carrier having a series of molds  
 40 in its periphery, with which cooperate a plurality of (preferably three) plungers, the first plunger forcing material into one of the molds with the desired pressure, the second  
 45 plunger giving to the briquet thus preliminarily formed the desired solidifying pressure, and the final plunger applying to the briquet an enormous final compression by which the required solidity thereof may be  
 50 secured. Preferably a series of these bricking-machines are arranged side by side, and the material is fed to the same by a trough having recesses therein in line with each machine, from which recesses the material  
 55 accumulated therein will be forced out into one of the molds by the first plunger. In this way I carry on the bricking operation at a minimum cost, since the machines are entirely automatic both in feeding and operation,  
 60 and I am enabled to produce an enormous number of the briquets with the expenditure of small power. The finished briquets from the bricking-machines are preferably baked, so that the required hardness  
 65 will be secured, and the apparatus therefore comprises an oven for accomplishing this result and which preferably is of the type in-

vented by me and described and claimed in my application for Letters Patent filed June 29, 1897, and numbered serially 642,814.  
 70 This oven comprises an inclosed chamber having a number of horizontally-arranged shafts at its upper end, each shaft carrying two or more sprocket-wheels near the ends  
 75 thereof and all being positively driven in the same direction. Sprocket-chains pass over the sprocket-wheels of the shafts and hang in loops within the oven, said chains carrying perforated semicylindrical buckets for receiving the material, which buckets travel  
 80 slowly through the oven. Heat is applied to the oven from furnace-boxes in any desired way. With briquets made of magnetite iron ore to which has been added a binding agent of the character described the baking should  
 85 progress at a temperature of from 400° to 500° Fahrenheit and for a period of about one hour. After leaving the oven the briquets are automatically dumped and are ready for the market.  
 90

In the accompanying drawing I illustrate diagrammatically the preferred embodiment of my improved apparatus for bricking pulverized materials.

71 is an elevator or conveyer for carrying  
 95 the pulverized iron ore, coal, or other substance to and depositing the same in a hopper 73, having a roller-feed 74 at its lower end. 75 is a heating device, which comprises a vertical chamber having a large number of  
 100 inclined baffle-plates therein, by which the material will be caused to pass through the chamber in zigzag paths. A distributor 76 is employed for subdividing the material equally over the entire area of the heater.  
 105 The lower end of the heater is provided with a roller-feed 76', by which the heated pulverized material will be fed to a conveyer 72, working over a platform 72', having openings  
 110 72" therein. Beneath said platform are located mixers 78, 78', 78", and 78"', which are preferably of the type described. The material after being mixed is fed from the mixer 78"' to an inclined guide or apron 79 and falls  
 115 upon the plates or screen-sections 80, over which it passes. Blasts of air are supplied to the material from a fan 81, so as to cool the material which accumulates in the hopper 82 at the lower end of the cooler. From this  
 120 hopper the material is carried upward by an elevator 83 to a conveyer 84, which works over a platform 84', having recesses or pockets 84" therein. These pockets are in line with bricking-machines 85, which are preferably  
 125 of the type described in my said application, the material accumulating in the pockets and being successively ejected therefrom by the preliminary plungers of said bricking-machines. The finished briquets from the  
 130 bricking-machines are deposited on a conveyer 86 and are dumped in the buckets 87 of the drier 88. These buckets are carried on sprocket-chains 88', which pass over sprocket-rollers 88" and hang in loops within

the oven, as I have described in my said application. The oven is heated in any suitable way—as, for instance, from the fire-box 89, supplied with forced draft through an air-duct 89'. The finished baked briquets are dumped from the buckets by the engagement of the latter with an inclined or wedge block 90, by which the buckets will be tilted, allowing the briquets to fall out on a chute or apron 91, from which they are carried by a conveyer 92 to the car 93 or to any suitable storage-receptacle.

The operation of my improved bricking apparatus will be as follows: The pulverized material is carried by the conveyer 71 and dumped into the hopper 73, from which it is removed by the roller-feed 74 and deposited into the distributor 76, being subdivided thereby and falling through the heating-chamber in a series of zigzag streams. From the heating-chamber the heated material will be carried by the conveyer 72 and distributed over the mixing devices 78, 78', 78'', and 78'''. A suitable binding substance is preferably added to the pulverized material in the first mixer 78—as, for instance, through a pipe 77—so that an abnormal quantity of the binder will be admixed with the material therein. As, however, the material advances from the mixer 78 to the mixer 78' and successively through the apparatus, additional quantities of the pulverized material will be added, so that the desired proportion of binder and pulverized material will be secured. In this way I obtain a very intimate admixture of the binding substance with the pulverized material. From the mixers the mixture passes down the apron or chute 79 through the cooler 80, where it is subjected to blasts of air and its temperature reduced to the desired point. This material is then carried by the elevator 83 to the conveyer 84 and is distributed behind the bricking-machines 85, by which it will be formed into briquets of

the desired size and shape. The briquets drop out upon the conveyer 86 and are carried by the buckets 87 through the oven, in which the briquets will be baked for the desired length of time and at the required temperature. The finished baked briquets will then be dumped onto the apron or chute 91, from which they will be carried to any desired point—as, for example, by the conveyer 92 to the car 93.

Having now described my invention, what I claim as new, and desire to secure by Letters Patent, is as follows:

1. An improved apparatus for bricking pulverized material, comprising a heater for heating the pulverized material, a mixer in which the heated pulverized material is admixed with a binding agent, a cooling device for reducing the temperature of such mixture, a bricking-machine for bricking the mixture, an oven for baking the finished briquets, and means connecting such devices for automatically progressing the material continuously through the apparatus, substantially as set forth.

2. An improved apparatus for bricking pulverized material, comprising a heater for heating the pulverized material, a series of mixers arranged in line, means for feeding a binding agent to the first of said mixers, means for distributing the pulverized material to a plurality of said mixers, a bricking-machine for bricking the pulverized material, an oven for baking the finished briquets, and means connecting such devices for automatically progressing the material continuously through the apparatus, substantially as set forth.

This specification signed and witnessed this 11th day of April, 1898.

THOMAS A. EDISON.

Witnesses:

J. F. RANDOLPH,  
FREDERICK C. DEVONALD.