

No. 759,358.

PATENTED MAY 10, 1904.

T. A. EDISON.  
MAGNETIC SEPARATING APPARATUS.

APPLICATION FILED JUNE 21, 1900.

NO MODEL.

2 SHEETS—SHEET 1.

*Fig. 1*

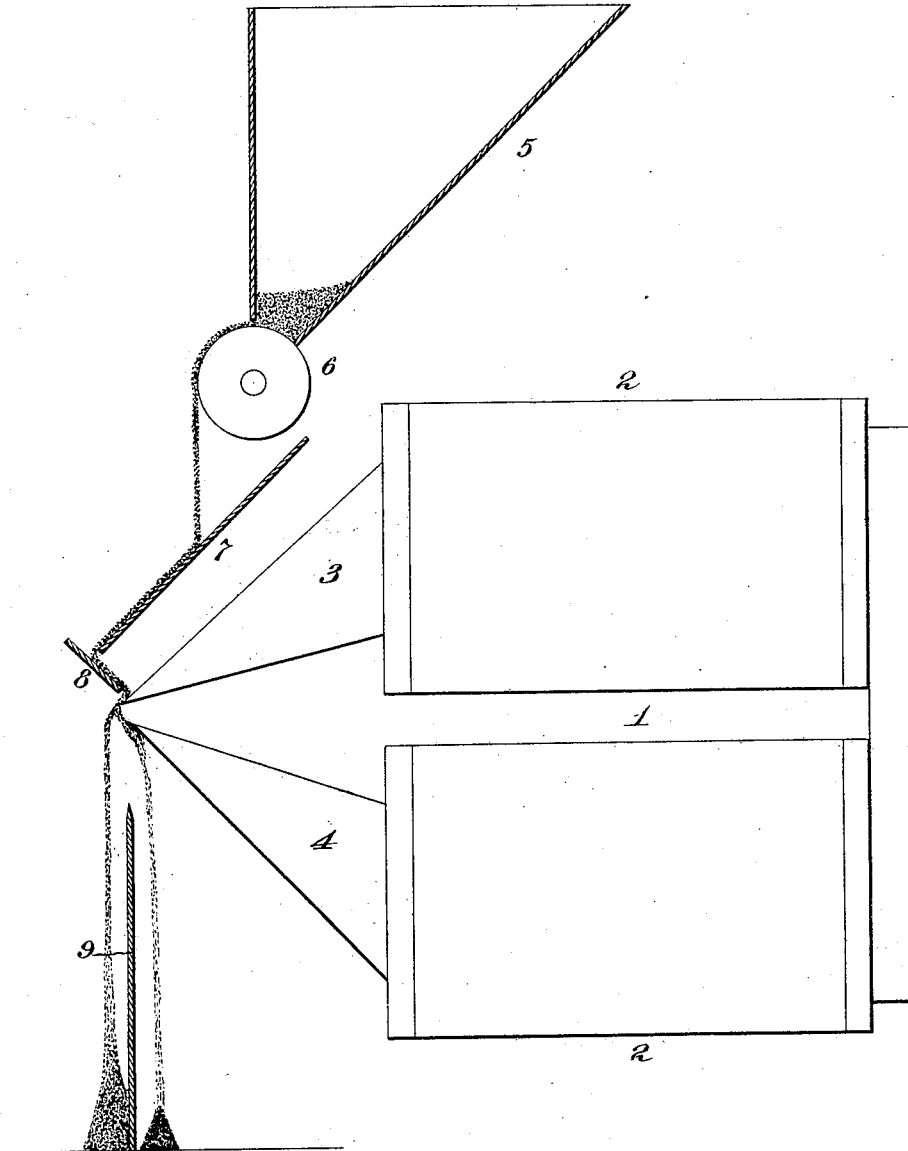

Witnesses:

*Jas. S. Coleman*  
*Jno. R. Taylor*

Inventor

*Thomas A. Edison*  
*Hyer Edwards & Ayer*  
Att'ys.

T. A. EDISON.  
MAGNETIC SEPARATING APPARATUS.

APPLICATION FILED JUNE 21, 1900.

NO MODEL.

2 SHEETS—SHEET 2.

Fig. 2

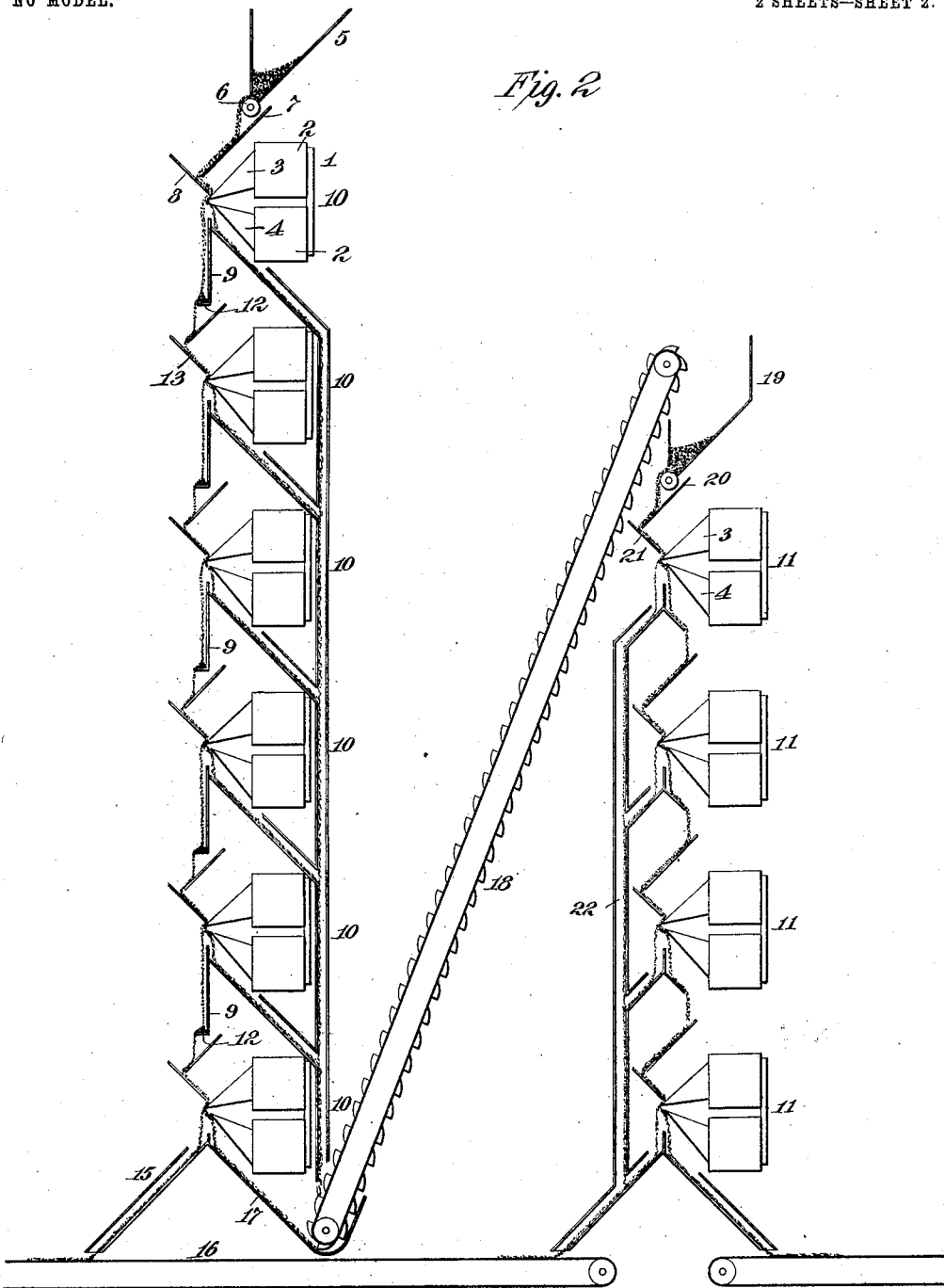

Witnesses:

*Jas. S. Coleman*  
*Geo. R. Taylor*

Inventor

*Thomas A. Edison*  
By *Ayer, Edmunds & Ayer*  
Att'ys.

# UNITED STATES PATENT OFFICE.

THOMAS A. EDISON, OF LLEWELLYN PARK, NEW JERSEY.

## MAGNETIC SEPARATING APPARATUS.

SPECIFICATION forming part of Letters Patent No. 759,358, dated May 10, 1904.

Application filed June 21, 1900. Serial No. 21,052. (No model.)

*To all whom it may concern:*

Be it known that I, THOMAS A. EDISON, a citizen of the United States, residing at Llewellyn Park, in the county of Essex and State of New Jersey, have invented a certain new and useful Improvement in Magnetic Separating Apparatus, of which the following is a specification.

My invention relates to an improved apparatus intended particularly for the separation from gangue and concentration of material which is only slightly magnetic, such as specular hematite, iron garnet, and franklinite; and my object is to provide an apparatus for the purpose of high efficiency, great capacity, and wherein the feed of the material to the magnetic devices and the separation of the magnetic and non-magnetic particles are effected by gravity and without the necessity of moving parts.

In carrying my invention into effect I employ one or more sets of magnetic separators, each being in the form of an ordinary double-coil electromagnet with extended tapering poles, one of which slightly overlaps the other to form a relatively narrow gap between them, and I deliver to the upper face of the overlapping pole a continuous but thin stream of the particles moving at as slow a rate as practicable, whereby the non-magnetic particles will be permitted to flow down the polar face and fall off therefrom at one side of a separating-board, while the magnetic particles will by the lines of magnetic force be attracted toward the other pole and will fall on the other side of said separating-board. Preferably a number, as stated, of such separators are used, divided into two series, in the first of which the particles rejected by the first separating device will be subjected to the succeeding separators, whereby a very rough concentration will be secured, while in the second set the material concentrated by the first separator will be subjected to the succeeding separators to secure a concentrated product of high percentage.

In order that the invention may be better understood, attention is directed to the accom-

panying drawings, forming part of this specification, and in which—

Figure 1 is a vertical sectional view of a magnetic separator embodying my present improvement, and Fig. 2 a corresponding view showing a series of such separators conveniently arranged for effecting a rapid but efficient concentration of slightly-magnetic material.

In both of the above views corresponding parts are represented by the same numerals of reference.

1 represents a magnet of common form, having two coils 2 2 and with two tapering poles 3 and 4, the former slightly overlapping the latter, as shown, whereby a narrow gap will be formed between them.

5 is a hopper in which pulverized magnetic and non-magnetic material may be placed, and 6 a roller-feed for feeding material from said hopper in a thin stream of the desired width, said stream being preferably only one or two particles thick. The material fed from the hopper 5 falls on a chute or apron 7 and before reaching the magnetic face of the pole 3 is checked by a checking-board 8, so that said material will fall upon the upper face of said pole, near the lower edge thereof, immediately after it has been brought to rest, wherefore the material will not acquire any appreciable velocity by the time it reaches the extreme lower edge of said pole. The non-magnetic particles falling over the edge of the pole 3 drop by gravity on one side of a separating-board 9, while the slightly-magnetic particles passing over said edge will be attracted by the lines of force between the two poles, and said magnetic or slightly-magnetic particles will fall on the other side of the separating-board 9, their trajectory being changed to an extent depending upon their magnetic affinity and upon the attraction of the poles. By thus feeding the mixed magnetic and non-magnetic particles directly to the polar face of a magnet and causing such particles to fall over the edge of the pole, so that the slightly-magnetic particles may be affected by the lines of force between said pole and an adjacent pole,

particles which are of extremely weak magnetic affinity may be effectively, rapidly, and accurately separated from their accompanying gangue, such separation being materially facilitated, as will be obvious, by bringing the particles substantially to rest immediately before they fall upon the magnetic face, so that such particles will drop over the edge of the pole almost from a state of rest and with a scarcely appreciable trajectory. Preferably the apparatus comprises, as stated, a series of these separators, a convenient arrangement for the purpose being shown in Fig. 2, illustrating ten separating devices divided into two sets 10 10 10 10 and 11 11 11 11, six of the separators being shown in the first set and four in the second set. The upper separator 10, with its feeding devices, is constructed in the same way as that described. The separating-board 9 is provided with a bottom 12, forming a ledge or shelf on which the rejected particles may accumulate as a pile, so as to be brought to rest, and from which the particles will be forced off by the accumulation of fresh accretions thereon, as will be understood, so that the particles will leave the pile of material on the shelf 12 practically from a state of rest. These particles flow down a chute or apron 13 as a thin wide stream, and their velocity is checked by a checking-board 14 before they strike the polar face of the upper pole of the magnetic separator immediately below, by which device a further withdrawal of any magnetic particles will be secured. In this way it will be noted that the particles rejected by the separators of the first set will be subjected successively to the succeeding separators, so that by the time the particles rejected by the uppermost separator have passed through all six of the separators of the first set the resulting gangue delivered from the bottom separator thereof will be approximately free of any magnetic or slightly-magnetic particles. This gangue passes down a chute 15 and may be carried off by a belt 16. The magnetic or slightly-magnetic particles withdrawn by the several separating devices are conveyed to a chute 17 and fall into the boot of an elevator 18, by which they are elevated to a hopper 19. From this hopper the particles are permitted to flow down an apron 20, their velocity being checked at the bottom thereof by a checking-shelf 21, after which the particles engage the upper pole of the first magnet of the second set, as shown. Any non-magnetic particles which may be rejected by this separator are permitted to pass to a chute 22, by which they are conveyed to the belt 16, while the magnetic particles withdrawn by this separator are permitted to pass to the second separator, where a further concentration thereof is effected, it being observed that with the effectors 11 the magnetic or partly-magnetic particles withdrawn

from the circulation by the several separators are again subjected to the separating action of the succeeding separators, whereby any non-magnetic particles which may be contained in the material will be permitted to escape. In this way I obtain a concentrate of high percentage.

While I prefer to arrange the separators in two sets, as explained, securing a very rough concentration in the first set and passing the rough concentrate to the final separators to secure a concentrate of high percentage, it will be understood that only a single one of the separators may be used alone or that a plurality of such separators may be used in other connections and combinations. It will be understood that before being submitted to the effect of the separating apparatus the material should be first treated in a separator of any desired form, by which the relatively highly-magnetic particles may be removed, since the presence of a considerable quantity of highly-magnetic particles in the material passing through the present apparatus would tend to immediately clog the gap between the two poles. I find in practice that the best results are secured when the construction of the magnets is such that the extreme edges of the poles are magnetically saturated and that when this is done the apparatus can be employed effectively in the separation of particles which are hardly appreciably magnetic.

While I have shown the separating apparatus as being divided into two series, the material from the first series being fed to the other by an elevator, it will be understood, of course, that where height is no object all of the separators in both series may be arranged in a single vertical bank.

Having now described my invention, what I claim as new, and desire to secure by Letters Patent, is as follows:

1. An improved magnetic separator, comprising two tapering magnetic poles sustained adjacent to each other with a narrow gap between them and with the upper pole slightly overlapping the lower, in combination with means for feeding pulverized magnetic and non-magnetic particles directly to the upper surface of the upper pole near its edge, whereby the magnetic particles will by the lines of force be deflected toward and fall below the under surface of the lower pole without passing through said gap, and a dividing-board below the lower pole for separating the magnetic and non-magnetic particles, substantially as set forth.

2. An improved magnetic separator, comprising two tapering magnetic poles sustained adjacent to each other with a narrow gap between them and with the upper pole slightly overlapping the lower, in combination with a deflecting-board arranged adjacent to the edge of the upper pole, means for feeding pulver-

ized magnetic and non-magnetic particles to  
the deflecting-board, whereby the velocity of  
such particles will be checked and they will  
be delivered to the upper pole near its outer  
5 edge, and a dividing-board below the lower  
pole for separating the magnetic and non-  
magnetic particles, substantially as set forth.

This specification signed and witnessed this  
11th day of June, 1900.

THOMAS A. EDISON.

Witnesses:

J. F. RANDOLPH,  
FRANK L. DYER.