

No. 821,624.

PATENTED MAY 29, 1906.

T. A. EDISON.
GAS SEPARATOR FOR STORAGE BATTERIES.
APPLICATION FILED NOV. 2, 1904.

Fig. 1.

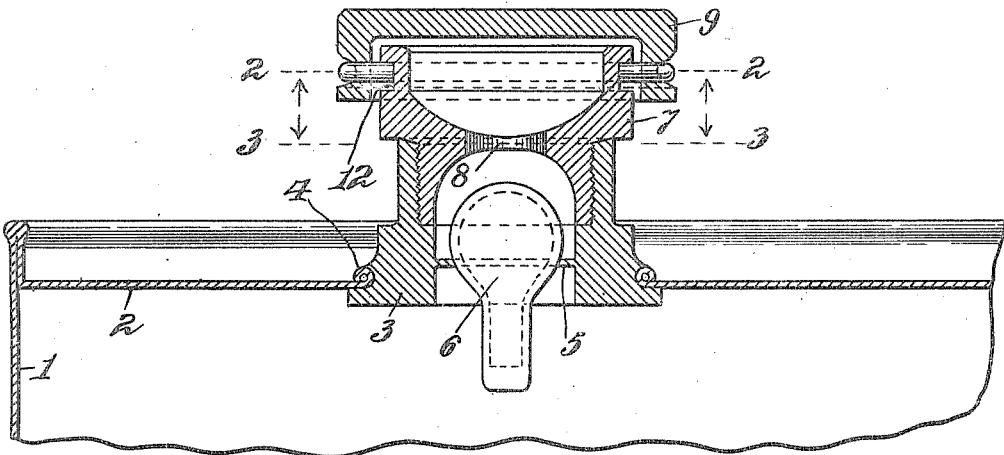

Fig. 2.

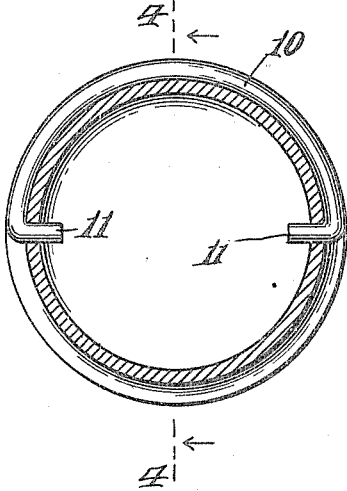

Fig. 3.

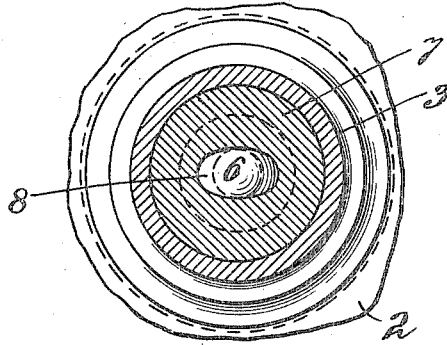
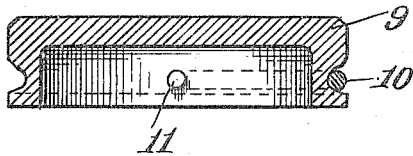

Fig. 4.



Witnesses
Edgeworth Courne
Wm. C. MacArthur

Thomas A. Edison
By his Attorney
Frank C. Piper

UNITED STATES PATENT OFFICE.

THOMAS A. EDISON, OF LLEWELLYN PARK, NEW JERSEY, ASSIGNOR TO
EDISON STORAGE BATTERY COMPANY, OF WEST ORANGE, NEW JERSEY,
A CORPORATION OF NEW JERSEY.

GAS-SEPARATOR FOR STORAGE BATTERIES.

No. 821,624.

Specification of Letters Patent.

Patented May 29, 1906.

Application filed November 2, 1904. Serial No. 231,064.

To all whom it may concern:

Be it known that I, THOMAS A. EDISON, a citizen of the United States, residing at Llewellyn Park, Orange, Essex county, New Jersey, have invented certain new and useful Improvements in Gas-Separators for Storage-Batteries, of which the following is a specification.

My invention relates to an improved gas-separator for storage batteries of the type employing the method described and claimed in my patent of the United States granted July 5, 1904, No. 764,183. Heretofore I have made use of a perforated diaphragm or gauze in the top of the separator-casing, through which the gases pass in a diffused and attenuated condition in order to prevent the possibility of an explosion within the can or receptacle. I find, however, that dust and dirt are likely to enter the can through this perforated diaphragm, thereby tending to clog the valve-seat and contaminate the solution to injuriously affect the operation.

The object of my present invention is to provide a construction wherein dust and dirt will be excluded from the receptacle and at the same time the operation of the separating valve will be augmented.

To this end the invention consists of providing the separator-casing with a cover or auxiliary valve which is normally closed to prevent the admission of any dust or dirt, but which will open by the accumulation of pressure beneath it to provide for the escape of the gases into the atmosphere, as I shall more fully hereinafter describe and claim.

In order that my invention may be better understood, attention is directed to the accompanying drawings, forming part of this specification, and in which—

Figure 1 is a vertical sectional view showing a portion of a storage-battery can with my present improvements applied thereto; Fig. 2, a horizontal section on the line 2 2 of Fig. 1; Fig. 3, a horizontal section on the line 3 3 of Fig. 1, and Fig. 4 a cross-section on the line 4 4 of Fig. 2.

In all the above views corresponding parts are indicated by the same numerals of reference.

A can 1 is provided with the top 2, in which

is secured the usual nipple or plug 3 by a beaded flange 4 in the ordinary way. The plug 3 is provided with a valve-seat 5 therein, with which coöperates a valve 6, the latter being made preferably of glass and hollow, so as to float, as I described in Letters Patent No. 785,297, granted March 21, 1905. Screwed into the plug or nipple 3 is a casing 7, having an opening 8 therein, as shown, said opening being so arranged that it cannot be closed if the valve is moved into engagement therewith. This may be accomplished by making the opening oval-shaped, Fig. 3, or in any other way.

At the top of the casing 7 is a valve-like cover 9, made heavy enough to normally rest firmly on the upper edge of the casing to form a seal at that opening. Partly surrounding this cover or auxiliary valve 9 is a wire 10, having inturned ends 11, which engage within a recess or channel 12, formed in the periphery of the casing 7, as shown, and of sufficient height to allow for some play of the inturned ends therein, thus allowing the auxiliary valve to move into and out of engagement with the seat formed by the upper edge of the casing. In operation the auxiliary valve will normally close the casing to exclude dust and dirt. As soon, however, as sufficient gas-pressure accumulates beneath the auxiliary valve it will be forcibly raised up, and the gas will be allowed to escape. This escape of gas takes place intermittently and is only momentary, and the velocity of the escaping gases is sufficiently high to prevent the entrance of any dust or dirt during the time the auxiliary valve is open. Furthermore, the opening of the auxiliary valve effects a sudden release of pressure above the separating-valve 6, so that the latter valve will also simultaneously open with the auxiliary valve to effect a separating operation, as heretofore described. Obviously, however, since the separating-valve is much lighter than the auxiliary valve it will operate more often and will continue to operate independently of the auxiliary valve until the pressure in the can becomes sufficiently high to overcome the weight of the auxiliary valve.

Having now described my invention, what I claim as new therein, and desire to secure by Letters Patent, is as follows:

1. In a storage battery, the combination with a valve-casing and separating-valve, of an auxiliary valve forming a cover for the casing and normally closing the same, as and 5 for the purposes set forth.
2. In a storage battery, the combination with a valve-casing and separating-valve, of an auxiliary valve forming a cover for the casing and normally closing the same and means 10 for limiting the movements of the auxiliary valve, as and for the purposes set forth.
3. In a storage battery, the combination of a valve-casing and separating-valve, of an auxiliary valve forming a cover for the valve-casing, and a series of projections carried by 15 the auxiliary valve and engaging a groove or channel in said casing, as and for the purposes set forth.
4. In a storage battery, the combination 20 with a valve-casing and separating-valve, of an auxiliary valve forming a cover for the valve-casing, and a series of connected projections carried by the auxiliary valve and engaging a groove or channel in said casing, 25 as and for the purposes set forth.
5. In a storage battery, the combination of a tubular member having a valve-seat and valve, an auxiliary valve-seat above said first 30 said auxiliary valve-seat and forming a protecting-cover for said tubular member, substantially as set forth.
6. In a storage battery, the combination of a tubular member having a valve-seat and valve, an auxiliary valve-seat above said 35 first valve-seat, a valve normally resting on said auxiliary valve-seat and forming a protecting-cover for said tubular member, and means for limiting the movement of said 40 cover-valve, substantially as set forth.
7. In a storage battery, the combination of a tubular member having a valve below the top thereof and an auxiliary valve covering the top of said tubular member and depending 45 around the same, substantially as set forth.
8. In a storage battery, the combination of a tubular member having a valve below the top thereof, an auxiliary valve covering the top of said tubular member and depending 50 around the same, and means for limiting the movement of said cover-valve, substantially as set forth.

This specification signed and witnessed this 29th day of October, 1904.

THOMAS A. EDISON.

Witnesses:

FRANK L. DYER,
J. W. AYLSWORTH.