

T. A. EDISON.
PRODUCTION OF PERFORATED STRIPS.
APPLICATION FILED JULY 1, 1910.

1,083,353.

Patented Jan. 6, 1914.

2 SHEETS—SHEET 2.

Fig. 2

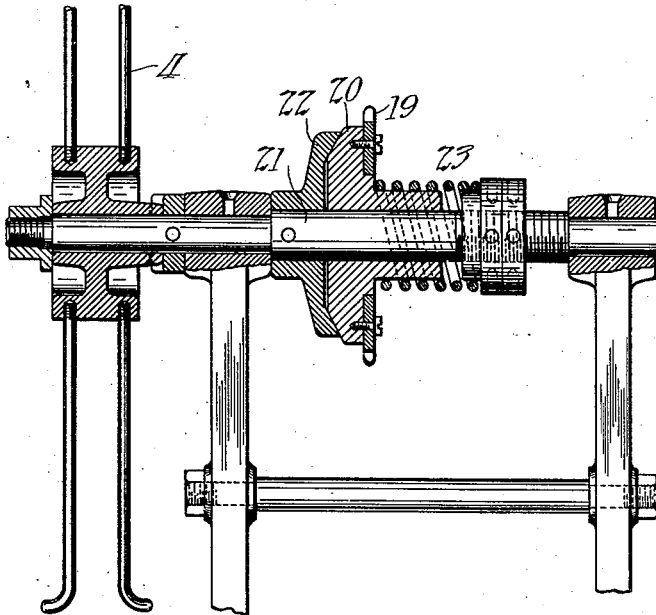

Fig. 3



Fig. 4



Fig. 5

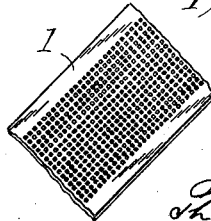

Witnesses:
Frank D. Lewis
Dyer Smith

Inventor:
Thomas A. Edison
by Frank L. Lewis
His Atty.

UNITED STATES PATENT OFFICE.

THOMAS A. EDISON, OF LLEWELLYN PARK, WEST ORANGE, NEW JERSEY, ASSIGNOR
TO EDISON STORAGE BATTERY COMPANY, OF WEST ORANGE, NEW JERSEY, A COR-
PORATION OF NEW JERSEY.

PRODUCTION OF PERFORATED STRIPS.

1,083,353.

Specification of Letters Patent.

Patented Jan. 6, 1914.

Application filed July 1, 1910. Serial No. 569,848.

To all whom it may concern:

Be it known that I, THOMAS A. EDISON, a citizen of the United States, and a resident of Llewellyn Park, West Orange, Essex
5 county, New Jersey, have made a certain new and useful invention in the Production of Perforated Strips, of which the following is a description.

My invention relates to the production
10 of perforated strips of thin sheet metal, such, for example, as are used for making pockets to contain the active material in storage batteries. Patent No. 870,024 was
15 granted to me November 5, 1907 upon an apparatus for producing perforated strips. The strips produced by this invention were perforated by a pair of cooperating perforating rolls between which the strip was
20 passed. I have found that objectionable burs are formed around each of the minute perforations produced by this operation, which burs somewhat obstruct the openings of the perforations, and also make the surface of the strip which forms the inner surface of the finished pocket in the storage
25 battery too rough. Accordingly, I now propose to grind down these burs to open the perforations sufficiently and also to reduce the roughness of the surface of the strips.

30 Accordingly, the objects of my invention are to produce an improved process for making perforated strips, including as a step the grinding off of the ends of the burs produced as above described, and also the provision of an improved apparatus by which
35 the process step above referred to may be efficiently carried out.

Reference is hereby made to the accompanying drawings forming part of this
40 specification, wherein the same numerals are used to designate corresponding parts in the several views, and in which—

Figure 1 represents in side elevation, mechanism for continuously grinding off the
45 burs from the surface of the perforated strip, by which mechanism the grinding step of my improved process may be carried out. Fig. 2 represents a cross section on line 2—2 in Fig. 1, parts being shown in
50 elevation. Figs. 3 and 4 represent enlarged sections through the perforated strip before and after grinding respectively, and Fig. 5 is a perspective side elevation of the perforated and ground strip.

Referring now to the drawings, the strip 55
1 is fed from the supply reel 2 past the emery wheel or similar grinding device 3 and onto take-up reel 4, the strip passing over idler 5 which is mounted in proximity to grinding wheel 3. Idler 5 is mounted in
60 a frame 6 which is preferably in the form of a hopper and which is adapted to be moved toward and away from emery wheel 3 in order to adjust the position of perforated strip 1 with respect to the grinder to regulate the amount of material taken off from
65 the strip by the grinder. The hopper-like form of the frame 6 serves to confine and collect the abraded material. Frame 6 is fed toward and away from the grinder by 70 means of the device shown diagrammatically at 7, which may comprise a screw and nut or equivalent device operated by handle 8. The strip is fed by means of toothed
75 roller 9, the strip passing between the same and a smooth roller 10. Roller 9 is mounted in bracket 11 carried by the frame 12 of the machine. Roller 10 is carried by bracket
80 13 pivotally mounted at 14 upon frame 12, screw 15 extending through bracket 13 and bearing upon frame 12, being adapted by its movement to cause bracket 13 to rock about pivot 14 to adjust the position of
85 roller 10 with respect to roller 9. Grinder 3 is driven by belt or chain connection 16 and the shaft of roller 9 by chain 17, take-up reel 4 being rotated from the shaft of roller 9 by chain 18.

Take-up reel 4 is preferably given a frictional connection with its driving shaft, so
90 that the feed provided by roller 9 to the perforated strip may be uniform, and undue strain upon the strip due to the increasing diameter of the strip wound upon take-up
95 reel 4 prevented. A suitable device for this purpose is illustrated in Fig. 2. As here shown, the chain 18 passes over the sprocket 19 which is mounted upon a friction member 20, which revolves upon shaft 21 upon which
100 reel 4 is secured. Friction member 20 is forced into frictional contact with cooperating friction device 22 secured upon shaft 21 by means of spring 23. Accordingly, shaft 21 and reel 4 are driven frictionally by the devices described from chain 18 so that as
105 the diameter of the roll of film upon reel 4 increases and the peripheral speed thereof increases over that of feeding roller 9, fric-

tion devices 20 and 22 will slip sufficiently to allow the strip 1 upon reel 4 to always have the same speed at the take-up reel as is imparted to it by feeding roller 9.

5 The appearance of the perforated strip 1 before grinding is illustrated in Fig. 3, and after grinding in Fig. 4, it being noted that the burs 24 have been ground down considerably and the ends of perforations 25
10 considerably widened thereby, as shown in Fig. 4. The appearance of the finished strip is indicated by Fig. 5.

Having now described my invention, what I claim is:—

15 1. In apparatus of the character described, in combination, a grinder, and means for continuously feeding a strip having ends and of perforated material past said grinder to reduce the burs surrounding the perfora-
20 tions on one side of the strip, substantially as described.

2. In apparatus of the character described, in combination, a grinder, a supply reel, a take-up reel, means for uniformly progress-
25 ing a strip of perforated material from said supply reel past said grinder and onto said take-up reel, and means for adjusting the position of the portion of said strip pass-
30 ing said grinder with respect to said grinder, substantially as described.

3. In apparatus of the character described, in combination, a grinder, and means for continuously feeding a strip of perforated

material past said grinder to reduce the burs surrounding the perforations on one
35 side of the strip and including a hopper adjustable relatively to the grinder, said hopper having means mounted therein for pressing the strip against the grinder, substan-
40 tially as described.

4. In apparatus of the character described, in combination, a grinder, and means for continuously feeding a strip having ends and of perforated material past said grinder to reduce the burs surrounding the perfora-
45 tions on one side of the strip and including an adjustable roller for pressing the strip against the grinder, substantially as described.

5. In apparatus of the character described, in combination, a grinder, means for con-
50 tinuously feeding a strip of perforated material past said grinder to reduce the burs surrounding the perforations on one side of the strip and including a take-up reel, and
55 means for driving the said feeding means, the said take-up reel having a frictional connection with said driving means, substan-
tially as described.

This specification signed and witnessed
this 30th day of June 1910.

THOS. A. EDISON.

Witnesses:

DYER SMITH,
FRANK D. LEWIS.