

T. A. EDISON.  
 PROCESS OF FORMING PHONOGRAPH STYLI.  
 APPLICATION FILED MAR. 23, 1910.

1,110,428.

Patented Sept. 15, 1914.

2 SHEETS—SHEET 1.

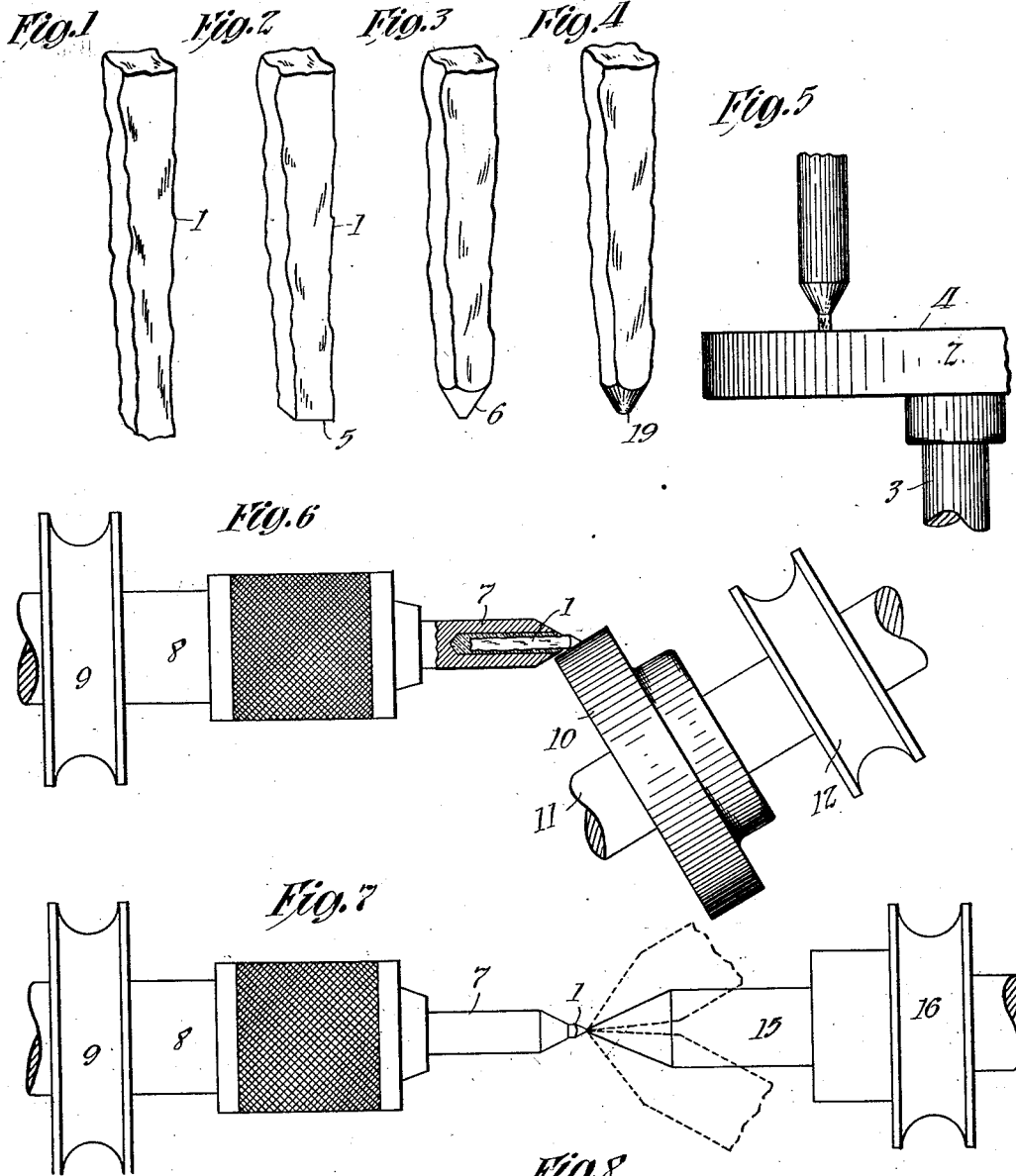

*Witnesses:*  
 Samuel D. Lewis  
 Dyer Smith

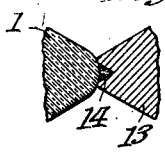

*Inventor:*  
 Thomas A. Edison  
 by *Francis W. Sears*  
 His Atty.

T. A. EDISON.  
 PROCESS OF FORMING PHONOGRAPH STYLI.  
 APPLICATION FILED MAR. 23, 1910.

1,110,428.

Patented Sept. 15, 1914.

2 SHEETS—SHEET 2.

Fig. 9

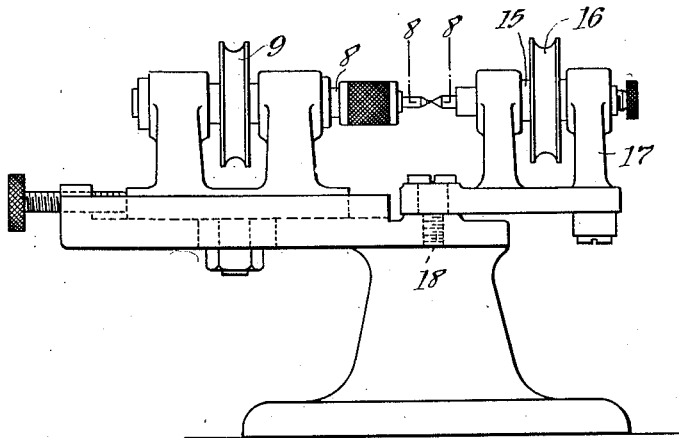

Fig. 10

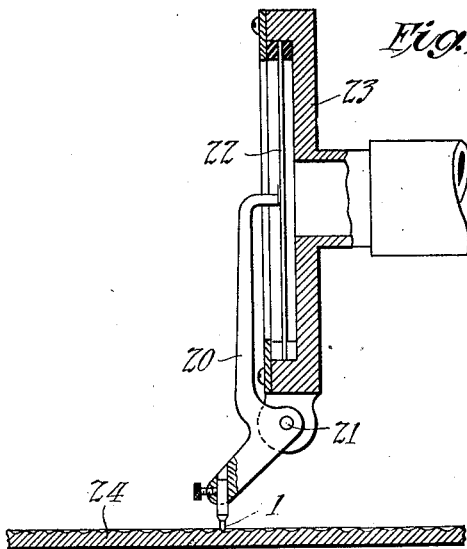

Fig. 11

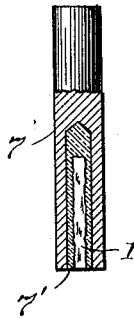
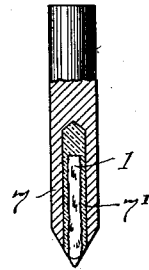

Fig. 12



*Witnesses:*

Frank D Lewis  
 Dyer Smith

*Inventor:*

Thomas A. Edison  
 by Frank L. Howes  
 His Atty

# UNITED STATES PATENT OFFICE.

THOMAS A. EDISON, OF LLEWELLYN PARK, WEST ORANGE, NEW JERSEY, ASSIGNOR  
TO NEW JERSEY PATENT COMPANY, OF WEST ORANGE, NEW JERSEY, A CORPORATION OF NEW JERSEY.

## PROCESS OF FORMING PHONOGRAPH-STYLI.

1,110,428.

Specification of Letters Patent.

Patented Sept. 15, 1914.

Application filed March 23, 1910. Serial No. 551,128.

*To all whom it may concern:*

Be it known that I, THOMAS A. EDISON, a citizen of the United States, and a resident of Llewellyn Park, West Orange, Essex county, New Jersey, have invented certain new and useful Improvements in Processes of Forming Phonograph-Styli, of which the following is a description.

My invention relates to phonograph styli, and more particularly to a process of forming reproducing styli of extremely hard material such as diamond, which styli are capable of operating upon records of very hard materials without wearing away or otherwise deteriorating.

My objects are the provision of an improved process for shaping such a styli, and the production of such a styli as an article of manufacture which is adapted to be used in combination with a suitable reproducer which is given a considerable weight, sufficient to hold the stylus firmly in contact with the record surface at all times, and also in combination with a record formed of material of such excessive hardness as to withstand the wearing action of the stylus and having formed thereon a record groove of fine pitch.

Other objects of my invention will appear from the following specification and appended claims.

Diamond has heretofore been mentioned among other materials as suitable for reproducing styli, but this has been a mere suggestion that in view of the exceeding hardness of the diamond, it would be of great value as a material from which reproducing styli might be made. The proper construction of a diamond stylus or a stylus formed of material substantially harder than sapphire, however, has never been disclosed to my knowledge, nor has such a stylus ever appeared commercially. I have found that an exceedingly hard record material such as that disclosed in applications of Aylsworth, Serial Nos. 496,060, plastic composition and process of manufacturing the same, filed May 14, 1909; 543,238, phenolic condensation product and method of preparing same, filed February 11, 1910; and 543,236, sound records and process for making the same, filed February 11, 1910, wears away the usual sapphire stylus to a considerable extent. The materials described in these ap-

plications are final condensation products of phenol, its homologues or polymers, and formaldehyde or hexa-methylene-tetramine or other substance containing the methylene radical  $\text{CH}_2$ , and in their final condition are much harder than celluloid, and in fact nearly approach glass as to their hardness. Such a record material or one of equivalent or great hardness, harder, for example, than celluloid, is preferably of the utmost value for the production of a molded phonograph record, since with a record formed of such material, a reproducer of considerable weight or provided with a heavy floating weight may be used with a consequent considerable improvement in the volume and quality of reproduction, if a stylus of sufficient hardness to withstand the wear caused by the hardness of the record is used therewith. Furthermore, with a record having an exceedingly fine pitch, it is necessary that the material be very hard in order that the fine walls between the grooves shall not be broken down in reproduction. A sapphire stylus is not appreciably worn when used in reproducing from such records, both disk and cylinder, as are now on the market, of which those formed from celluloid are probably the hardest. When, however, the record material is substantially harder than celluloid, a sapphire stylus quickly wears out, and accordingly, I have constructed a diamond stylus which is adapted to coact with such a record and to withstand the consequent wear. It should be noted that as a test, over 300 reproductions were made under my direction with a reproducer weighing from 2 to 5 ounces and provided with a diamond stylus such as I will describe, operating upon a record of the type having a vertically undulating groove and formed of a phenolic final condensation product, described in the above mentioned applications of Aylsworth, compounded with finely divided wood pulp. This test resulted in no appreciable wear, either of the record surface or of the stylus.

Reference is hereby made to the accompanying drawings forming part of this specification, and in which—

Figure 1 represents in perspective a diamond splint from which my improved stylus is formed. Figs. 2, 3 and 4 are similar views of the splint showing the different stages

of operation in the shaping of the reproducing point thereon. Fig. 5 is a diagrammatic view showing the method of lapping the end of the splint to a flat surface, which is preferably the first step in my improved process. Fig. 6 is a diagrammatic side elevation partly in cross section showing the method of holding the stylus and lapping or grinding a taper upon the end thereof. Figs. 7 and 9 are respectively a partial plan and side elevation of suitable apparatus for performing the final step of my process, consisting in rounding the end of the stylus. Fig. 8 is an enlarged cross section on line 8-8 of Fig. 9 showing a detail of construction. Fig. 10 is a partial cross section through a reproducer provided with my improved diamond stylus traveling in the record groove of a suitable sound record formed of hard material such as described above. Figs. 11 and 12 are side elevations of the splint in rough and finished condition respectively, entirely inclosed within a holder of soft metal, illustrating steps in a modification of my process.

Particular suitable mechanism by which my process may be carried out will be described for the sake of clearness, but it is to be understood that my process is not limited to such mechanism.

Referring to the drawings, my improved stylus is formed from a diamond splint, such as indicated at 1. Splints such as that illustrated and of suitable size may be obtained in the market, or they may be prepared by first cleaving a diamond into flat plates and then notching these plates with diamond dust and breaking the same into splints. Such splints are of various shapes and are more or less irregular and rough in appearance. In the formation of a stylus from such a splint, I prepare only one end of the splint, since the roughness and irregularity of the body of the splint are really advantageous, since they aid in firmly holding the splint in the chuck during the formation of the stylus and in the stylus lever after the stylus is completed.

Having obtained the splint, I preferably first grind the end thereof to a flat surface by means of a revolving lap wheel charged with diamond dust. In Fig. 5 I have illustrated diagrammatically a lap wheel 2 which revolves about spindle 3, and being charged with diamond dust upon its surface 4, grinds the flat surface 5 upon the end of splint 1, as indicated in Fig. 2. During this operation, the splints may be secured in a suitable holder. Having ground the flat surface 5 upon the end of the splint, the next operation is grinding the sides of the splint adjacent to the flat end 5 to a taper, resulting in the production of a conical surface 6 upon the end of the splint, as shown in Fig. 3. The splint 1 may be se-

cured in a suitable holder 7 of brass or other suitable material by cement, which holder is chucked in a lathe such as indicated in Fig. 6, in which the spindle 8 is rotated by means of a belt passing over wheel 9, or by other power connection. While the splint 1 is being rotated, it is ground at a suitable angle, preferably of approximately 30 degrees by means of the lap wheel 10, which is charged with diamond dust and mounted upon shaft 11, which may be adjusted at any suitable angle and rotated by any suitable means indicated diagrammatically by the belt wheel 12. If desired, the two steps of the process so far described may be transposed, and the sides of the splint adjacent to the end first ground to a taper and the rough end surface remaining then flattened. Or if the end of the splint is sufficiently regular, it may not be necessary to flatten the end at all, and the same may be left rough. After the end portion of the splint has been reduced sufficiently so that the point or flat surface 5 is of sufficiently small area, the latter is rounded and polished by any suitable means, such as the ball polishing machine shown diagrammatically in Figs. 7 and 9. As here shown, the splint 1 secured in a holder such as 7 is chucked in a lathe having a rotating spindle such as 8. The end of the splint 1 is rounded and polished by means of the grinding tool 13 which is provided with a concave surface of the shape and size to which it is desired to round the end of the splint.

The grinding surface of the tool 13 may be charged with diamond dust mixed with oil, as indicated in Fig. 8 at 14. Either the stylus or the tool grinding the same should partake of an oscillatory movement during the rotation of the stylus. In the drawings, I have illustrated the grinding tool 13 as suitably mounted in a spindle 15, which is revolved by means of belt wheel 16, the spindle and belt being mounted in a holder 17, which is pivoted as shown at 18 directly below the end of the stylus being rounded, so that during the grinding operation, the spindle 15 may oscillate about the surface being ground, as indicated by the positions of the spindle 15 shown in dotted lines in Fig. 7. The end of the stylus when rounded is shown in Fig. 4 at 19, the said figure representing the completed stylus. The curve 19 should be of the proper dimensions to travel within the exceedingly minute sound record groove, the conical surface 6 of the splint preferably running smoothly into the curve 19 of the record-engaging surface of the stylus. In the case of a vertically undulating record having 150 threads to the inch, I have found that a stylus in which the curve 19 has a diameter of .008 inch gives good results.

A modification of the process outlined above, which I have found valuable, consists in inclosing the entire splint in a holder of brass or other soft material, and subjecting the splint inclosed in the holder to the same grinding operations as described above, where the splint was illustrated as projecting from the holder. In this method, in grinding the splint the adjacent portions of the holder are also ground away, the holder protecting the splint against breakage during the operations in the same manner as the wood of a lead pencil protects the lead in sharpening the pencil. This is of value since otherwise the splint is likely to be broken during grinding. In Fig. 11 I have illustrated the splint 1 entirely inclosed within holder 7 and held therein by cement 7'. The lower end of the holder and splint shown in Fig. 11 is ground flat, if necessary, and the sides of the holder and the inclosed splint ground to a taper and the end of the splint rounded in the holder as shown in Fig. 12.

The methods above indicated for shaping styli give them great strength and seem to be the only practical methods of shaping them without having recourse to a large amount of grinding, which results in a loss of strength. A stylus so formed is adapted to track either a disk or a cylindrical record. In Fig. 10, I have illustrated a stylus 1 connected by lever 20, pivoted at 21, to diaphragm 22 of reproducer 23. This reproducer is preferably of considerable weight, as, for example, from 3 to 5 ounces or more, which weight holds stylus 1 firmly in engagement with the record groove of record 24, which is preferably formed of the final phenolic condensation product above referred to.

Having now described my invention, what I claim and desire to protect by Letters Patent is as follows:

1. The process of forming phonograph styli and the like which consists in substantially inclosing a small piece of very hard material within a holder of comparatively soft material, grinding the end of the holder and inclosed piece to a cone shape, and then rounding the point of the piece while still secured in the holder, substantially as described.

2. The process of forming phonograph styli and the like which consists in substantially inclosing a small piece of very hard material within a holder of comparatively soft material, grinding the end of the holder and inclosed piece to a cone shape, and then rounding the point of the piece by causing relative rotation and oscillation of the holder with the piece therein and a tool in engagement with said point, substantially as described.

3. The process of forming phonograph styli and the like which consists in securing a small piece of very hard material in a holder of comparatively soft material in such a manner as to substantially inclose the piece therein, lapping the end of the piece to a flat end surface, grinding the sides of the piece adjacent said end surface to a cone shape tapering down to the remaining portion of said end surface and then rounding the said end, substantially as described.

This specification signed and witnessed this 19th day of March 1910.

THOMAS A. EDISON.

Witnesses:

PURSELL EGGLESTON,  
HERMAN WOLKE.

It is hereby certified that in Letters Patent No. 1,110,428, granted September 15, 1914, upon the application of Thomas A. Edison, of Llewellyn Park, West Orange, New Jersey, for an improvement in "Processes of Forming Phonograph-Styli," errors appear in the printed specification requiring correction as follows: Page 1, lines 17 and 18, for the word "stili" read *stylus*; same page, line 64, strike out the word "preferably"; page 2, line 32, before the word "formed" insert the word *preferably*; and that the said Letters Patent should be read with these corrections therein that the same may conform to the record of the case in the Patent Office.

Signed and sealed this 6th day of October, A. D., 1914.

[SEAL.]

R. F. WHITEHEAD,  
*Acting Commissioner of Patents.*