

T. A. EDISON.  
SOUND RECORDING APPARATUS.  
APPLICATION FILED JUNE 9, 1910.

1,126,428.

Patented Jan. 26, 1915.

*Fig. 1*

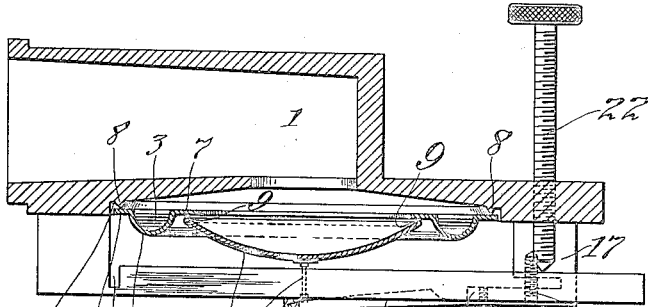

*Fig. 3*

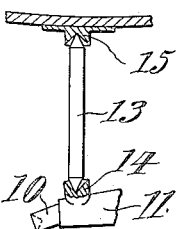

*Fig. 2*

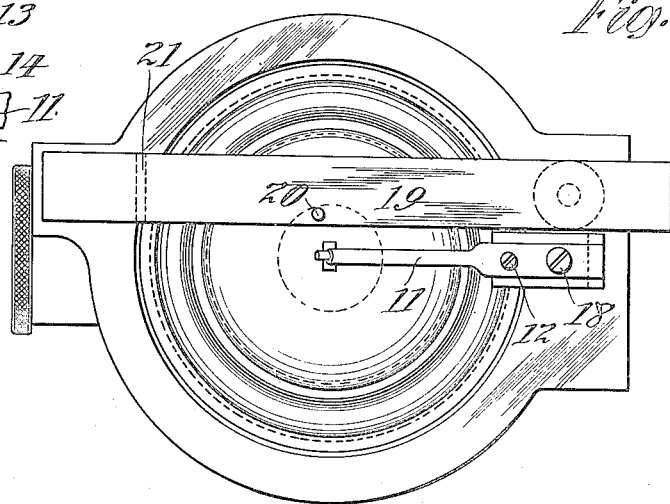

*Witnesses:*  
Robert M. Sutphen.  
Dyer Smith

*Inventor:*  
Thomas A. Edison  
by Frank L. Owen,  
Tris Alley

# UNITED STATES PATENT OFFICE.

THOMAS A. EDISON, OF LLEWELLYN PARK, WEST ORANGE, NEW JERSEY, ASSIGNOR TO  
NEW JERSEY PATENT COMPANY, OF WEST ORANGE, NEW JERSEY, A CORPORATION  
OF NEW JERSEY.

## SOUND-RECORDING APPARATUS.

1,126,428.

Specification of Letters Patent.

Patented Jan. 26, 1915.

Application filed June 9, 1910. Serial No. 566,069.

*To all whom it may concern:*

Be it known that I, THOMAS A. EDISON, a citizen of the United States, and a resident of Llewellyn Park, West Orange, Essex county, New Jersey, have invented certain new and useful Improvements in Sound-Recording Apparatus, of which the following is a description.

My invention relates to devices for recording sound, and is an improvement on the structure described in my application Serial No. 556,469, filed April 20, 1910, which application has resulted in United States Patent No. 1,019,441, dated March 5, 1912. In the application referred to was described and claimed a recorder having a diaphragm comprising a flexible ring having the upper surface of its outer edge resting in contact with a knife edge carried by the sound box, and a rigid arched circular central member, the outer edge of which constituted a knife edge and pressed against the lower side of the inner edge of the flexible ring. The stylus was rigidly connected with the center of the rigid inner diaphragm member, and a strong upward stress given to the whole diaphragm, by means of a spring member upon which the stylus was carried, to hold the members of the diaphragm in position and also to prevent excessive movement of the diaphragm away from the recording surface. This resulted in a construction of sufficient sensitiveness to respond to sound waves of little power, and one which also was so formed as to largely prevent excessive movements of the diaphragm away from the recording surface under the influence of sound waves of great amplitude.

The object of my present invention is to improve upon the construction just described.

I now propose to form the flexible ring member of the diaphragm of acetyl cellulose, or nitro-cellulose, or cellulose xanthate, (viscose cellulose), paper and like material whose porous structure permits of large flexing with very little power, a property absent in metals, glass and similar non-porous materials. I also now form the ring member with a wide central ring-shaped corrugation, the knife-edges of the sound box and the rigid central diaphragm member respectively contacting narrow flat portions of the ring member on each side of

the corrugation. By this means the action of the diaphragm is changed, so that, while the diaphragm is just as sensitive to weak sound waves of small amplitude, it is not moved away from the recording surface so far under the influence of sound waves of great amplitude. It is worthy of note that when such a corrugation is formed on a ring member made of metal of other substance having different properties from those of the materials mentioned, the vibrations of the same are deadened, so that no successful record can be made. Also by this construction, the possibility of buckling in the ring member is lessened, as is also the tendency of the flexible member to vibrate in parts. Another improvement, which is described and claimed herein, over the construction shown in my previous application, consists in making a jointed connection between the diaphragm and the spring lever carrying the stylus instead of connecting the parts rigidly. As the stylus moves up and down in recording, it also moves in an arc about the point at which the spring lever carrying the stylus is supported. If the stylus and spring lever are rigidly connected to the center of the diaphragm, the movement of the stylus in an arc tends to force the diaphragm to one side, or to cause the same to buckle. I overcome this difficulty, as stated, by making a jointed connection between the spring lever and the diaphragm, so that the latter may freely move in straight lines toward and away from the recording surface without being acted upon by any forces through the connection from the stylus tending to move it in any other direction.

In order that a clear understanding of my invention may be had, attention is hereby directed to the accompanying drawings, forming part of this specification, and in which—

Figure 1 represents a vertical central cross section through a sound recorder embodying one form of my invention; Fig. 2 is a bottom plan view thereof; and Fig. 3 is an enlarged detail view partly in section, showing my improved connection between the diaphragm and stylus.

Referring to the drawings, the sound box 1 may be provided with a recess 2 to receive and guide the diaphragm. The latter consists of a flexible outer portion 3 which is

preferably annular or ring-shaped, and an inner non-flexible portion 4. The flexible annulus 3 is preferably formed of a cellulose composition, such as paper, acetyl cellulose, 5 nitro-cellulose, decomposed viscose cellulose, or other porous easily flexing material. The annulus 3 is likewise preferably provided with a wide stiffening corrugation 5 which may be either downwardly directed as 10 shown or upwardly directed, and which occupies nearly the entire width of the ring, leaving very narrow flat portions 6 and 7 upon each side of the same. The flat portions as shown, are substantially narrower 15 than the corrugation. The ring 3 is placed within recess 2 of sound box 1 without touching the sides of the same and is supported by knife edge 8 extending downwardly from sound box 1 within recess 2, 20 said knife edge being positioned to engage the upper surface of the outer flat portion 6 of ring 3. The stiffening corrugation 5 extends outwardly nearly to knife edge 8 leaving a very narrow portion of the ring between the corrugation and the knife edge. 25 The ring 3 is not secured to the sound box by wax, rubber, or in any other way. The rigid or non-flexible portion 4 of the diaphragm is given the form of an arch as shown, or is otherwise formed so that it will not be flexed by the vibrations of the sound waves upon it. This rigid member 4 is preferably circular in form with its edge bent sharply upward, as shown at 9, thus forming a knife edge contacting the lower side 30 of the inner flat portion 7 of ring 3, quite near the inner edge of corrugation 5. The recording stylus 10 is carried by spring lever 11, the other end of which is flattened and secured within the sound box by 40 screw 12.

In assembling the recorder, the ring member 3 of the diaphragm is placed in position upon knife edge 8 with the upper surface of 45 flat portion 6 of the ring adjacent the outer edge of corrugation 5 contacting the same, and the non-flexing member 4 of the diaphragm is then placed in position with its sharp peripheral edge 9 contacting the under side of flat portion 7 of ring 3 near its 50 inner edge, and also near the inner edge of corrugation 5. A small pin 13 having pointed or rounded ends is then placed in position between the end of spring member 11 and the center of the rigid diaphragm 55 member 4, which are provided with conical or rounded holes or sockets 14 and 15 in which the ends of pin 13 rest, the spring member 11 being given a strong inward flexure, so that pin 13 and the diaphragm 60 members are held in position, and a strong upward stress given to the whole diaphragm.

The construction described provides a pin and socket or universal connection between 65 the stylus and diaphragm, so that as the

stylus moves in an arc about screw 12, the pin 13 will turn slightly in its sockets 14 and 15, without binding or buckling the diaphragm or otherwise affecting its straight line movement toward and away from the 70 recording surface.

Instead of the universal connection described, I might pivot the pin 13 to the diaphragm and the spring lever 11 in such a manner as to permit relative movement of 75 the pin only in a plane parallel to the axis of the spring lever 11, but the construction shown is simpler and better.

The amount of flexure of spring member 11 may be adjusted in any suitable manner. 80 As shown in the drawings, I prefer to secure spring member 11 as by screw 12 to an arm 16 of block 17 secured to the sound box. Block 17 is formed of brass or other comparatively elastic material, and arm 16 may 85 be moved somewhat toward or away from block 17 by adjusting screw 18, threaded through arm 16 and block 17, and thereby increasing or decreasing the initial flexure of spring member 11 carried by arm 16. 90 Lever 19 carrying tracking member 20 may be used if desired, the lever and the tracking member 20 carried thereby being adjustable to regulate the depth of cut permissible for recording stylus 10. Lever 19 may be of 95 comparatively elastic material, such as brass, cut away as shown at 21 to produce a flexible joint or hinge, the screw 22 bearing on the end of the lever to regulate the position of tracking member or ball 20. 100

Of the substances of which I have stated the ring member 3 may be formed, I prefer to use acetyl cellulose, since this material seems to hold its shape better than any 105 other. Diaphragms well adapted to the desired purpose may, however, be formed of any of the substances named, while I have found that glass, mica, and metals are not adapted for this purpose.

Having now described my invention, what 110 I claim and desire to protect by Letters Patent as follows:

1. In sound recording apparatus, the combination with a centrally stiffened ring diaphragm formed of flexible material and a 115 non-flexible central member bridging the opening of the ring and in contact therewith, of a recording stylus connected to the non-flexible member, and means for applying an elastic pressure on the stylus to hold the 120 flexible and non-flexible members in engagement, substantially as described.

2. In sound recording apparatus, the combination of a knife edge support, a two-part diaphragm comprising a stiffened ring member having a flexible outer edge freely 125 mounted on said support with the latter contacting the flexible outer edge thereof and a non-flexible member bridging the opening of said ring and making contact therewith, a 130

recording stylus and a spring arm carrying the stylus and by its tension imposing an initial flexure on the diaphragm, substantially as described.

5 3. In a sound recording apparatus, the combination with a sound box, of a stiffened ring diaphragm having a flexible portion mounted in contact with said sound box, a non-flexible member mounted to contact said ring diaphragm, but not attached thereto, and a recording stylus connected to said non-flexible member, substantially as described.

10 4. In sound recording apparatus, the combination with a supporting knife edge, of a diaphragm comprising a ring of flexible material having outer and inner flat portions adjacent its outer and inner edges respectively, and a corrugated portion intermediate said flat portions, said outer flat portion bearing on said knife edge, a non-flexible member mounted with its outer edge contacting said inner flat portion but not attached thereto, and a stylus connected to said non-flexible member, substantially as described.

15 5. In sound recording apparatus, the combination with a recording stylus, of a diaphragm connected thereto comprising a rigid inner portion and an outer portion mounted to vibrate therewith, and formed of acetyl cellulose, substantially as described.

20 6. In apparatus of the class described, the combination with a stylus, of a diaphragm connected thereto comprising a rigid inner portion and an outer ring portion mounted to vibrate therewith, but not attached thereto, said outer ring portion being formed of a flexible porous organic material with a central ring-shaped corrugation therein, and means for supporting said diaphragm contacting said ring portion outside of said corrugation, substantially as described.

25 7. In apparatus of the class described, the combination with a stylus, of a diaphragm connected thereto and comprising a rigid inner portion and an outer portion formed of flexible material and having central stiffening means, a knife edge contacting the upper surface of the outer portion on one side of said stiffening means, said rigid inner portion having a sharp outer edge contacting the under surface of said outer portion on the side of said stiffening means opposite that contacted by said knife edge, and elastic means for holding said inner portion in contact with said outer portion, substantially as described.

30 8. In sound recording apparatus, the combination with a sound box, of a stiffened

diaphragm member mounted therein but not secured thereto and having flexible free edges; a non-flexible diaphragm member mounted to vibrate with said stiffened diaphragm member but not secured thereto, and a stylus connected to said non-flexible diaphragm member, substantially as described.

35 9. In sound recording apparatus, the combination with a recording stylus and a yielding member carrying the same, of a diaphragm and a connection between said member and diaphragm having universal movement with respect to said member and diaphragm, said yielding member normally exerting a pressure on said connection to force the same toward said diaphragm, substantially as described.

40 10. In sound recording apparatus, the combination with a sound box, of a flexible ring diaphragm mounted therein, said diaphragm having an annular corrugation therein and being formed of a compound of cellulose, a non-flexible member mounted to contact one edge of said ring but not secured thereto, and a recording stylus connected to said non-flexible member, substantially as described.

45 11. In sound recording apparatus, the combination with a sound box, of a stiff corrugated annular diaphragm member mounted therein but not secured thereto and having a free flexible inner edge, a support engaging said member adjacent its inner edge but not secured thereto, and a stylus connected to said support and adapted to vibrate with said diaphragm member, substantially as described.

50 12. As a new article of manufacture, an annular diaphragm of acetyl cellulose, substantially as described.

55 13. As a new article of manufacture, an annular flexible diaphragm of acetyl cellulose formed with a concentric annular stiffening corrugation and flat portions on the inside and the outside of the same, substantially as described.

60 14. In sound recording apparatus, the combination with a recording stylus and a resilient member carrying the same, of a diaphragm, and connecting means having a universal connection with said resilient member and also with said diaphragm, substantially as described.

This specification signed and witnessed this 7th day of June 1910.

THOS. A. EDISON.

Witnesses:

DYER SMITH,  
J. M. CANFIELD.

This Page Not Available

This Page Not Available