

T. A. EDISON.
 CONTACT FOR ELECTRICAL APPARATUS.
 APPLICATION FILED JUNE 13, 1912.

1,152,616.

Patented Sept. 7, 1915.

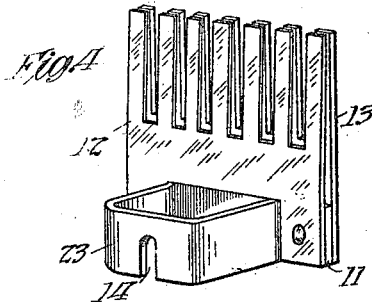
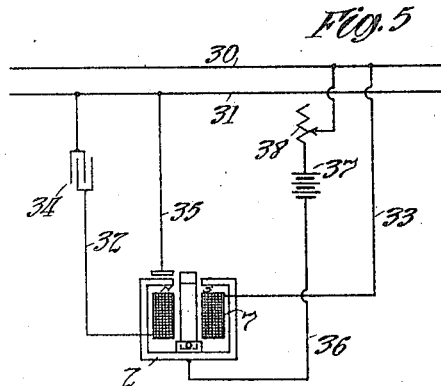
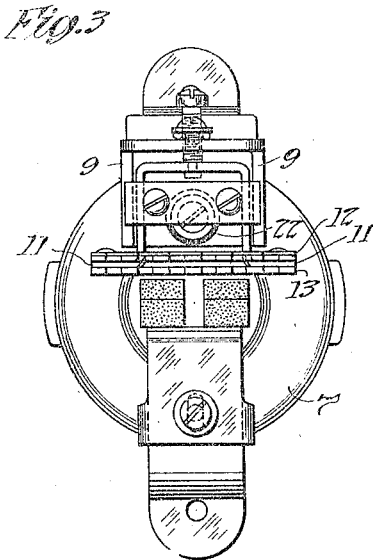
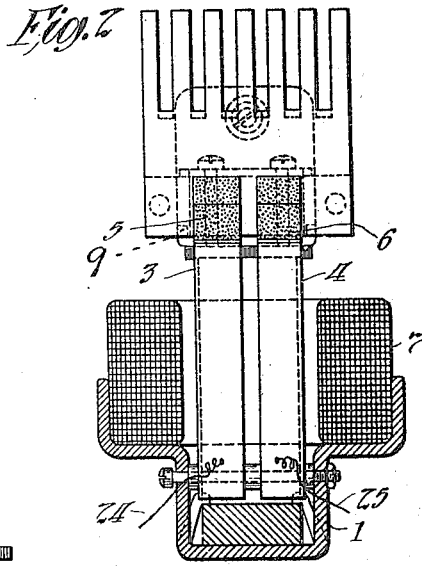
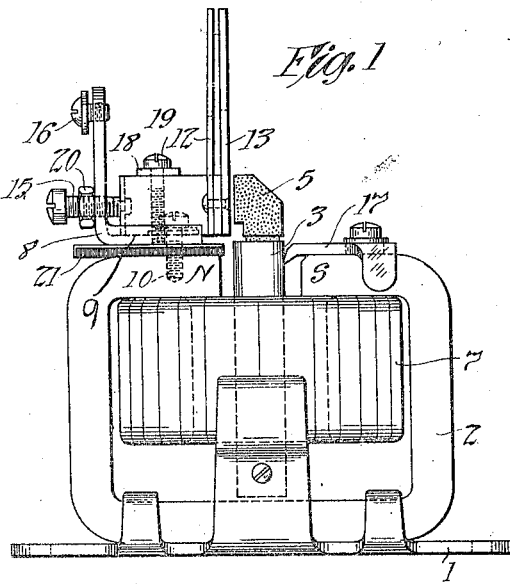

Witnesses:
 Grant Lewis
 Harry Lanahan

Inventor:
 Thomas A. Edison
 by Grant C. Pomeroy
 his Att'y.

UNITED STATES PATENT OFFICE.

THOMAS A. EDISON, OF LLEWELLYN PARK, WEST ORANGE, NEW JERSEY, ASSIGNOR TO
NEW JERSEY PATENT COMPANY, OF WEST ORANGE, NEW JERSEY, A CORPORATION
OF NEW JERSEY.

CONTACT FOR ELECTRICAL APPARATUS.

1,152,616.

Specification of Letters Patent.

Patented Sept. 7, 1915.

Application filed June 13, 1912. Serial No. 703,368.

To all whom it may concern:

Be it known that I, THOMAS A. EDISON, a citizen of the United States, and a resident of Llewellyn Park, West Orange, Essex county, New Jersey, have invented certain new and useful Improvements in Contacts for Electrical Apparatus, of which the following is a description.

My invention relates to improvements in contacts which are particularly adapted for use in alternating current rectifiers of the vibrating type, but also adapted for use in other forms of electrical apparatus. Where contacts are employed for making and breaking circuits carrying considerable current, difficulties are met with, due to sparking upon breaking the circuit. In my application Serial No. 668,611, dated December 30, 1911, I have disclosed and claimed alternating current rectifiers similar to that described herein, in which carbon contacts are employed on the vibrating armatures. Said carbon contacts cooperate with block contacts of metal and greatly reduce the tendency to spark.

My present invention has for its object the provision of a simple and efficient form of contact adapted to radiate and dissipate the heat generated by the contacts in an efficient manner, thereby preventing excessive rise of temperature, and still further reducing the tendency to spark.

My invention is described more fully hereinafter and claimed.

For the further description of my invention reference is had to the drawings which accompany and form a part of this specification and in which—

Figure 1 is a side elevation of a rectifying device provided with one embodiment of my improved contact; Fig. 2 is a vertical section of Fig. 1; Fig. 3 is a plan view of the same; Fig. 4 is a perspective view of the contact; and Fig. 5 is a diagrammatic view showing the rectifier connected in the rectifying system.

In the drawings, a frame or base is shown at 1, upon which is mounted a permanent magnet 2 having an almost completely closed magnetic circuit. Armatures 3 and 4 are pivotally mounted on the frame so as to be capable of vibration in the gap of the magnet 2. The armatures 3 and 4 are provided with contacts 5 and 6 respectively, prefer-

ably made of carbon and secured to the armatures in any suitable manner. A coil 7 surrounds the armatures 3 and 4 and is supported between the magnet 2 and upwardly extending lugs or projections of the frame 1. An L-shaped member 8 is secured to one of the poles of the magnet 2 and is insulated therefrom by insulating material 21. The insulating material 21 rests on the magnet 2 and the horizontal arm of the L-shaped member 8 rests on the insulating material and is secured to the magnet by means of a screw 10, which is provided with insulation 22 so as to insulate the L-shaped member 8 from the magnet. The horizontal portion of the L-shaped member 8 is provided with guides 9 between which is received the adjustable stationary contact. The adjustable stationary contact has a U-shaped portion 23 which is provided with outwardly extending portions 11. Plates 12 and 13 of suitable material, such as copper, are secured on each side of the outwardly extending projections 11 and the plates 12 and 13 and the extensions 11 are riveted together. The copper plates 12 and 13 extend vertically upward, have considerable mass, and are sub-divided in order to provide considerable area for radiating and dissipating heat. In the form of contact which I have illustrated, the plates 12 and 13 are provided with upwardly extending teeth, making of each of the plates a comb-like member. The vertical arm of the L-shaped member 8 is provided in its lower portion with an adjusting screw 15, which near its inner end has a reduced portion extended through an opening 14 in the U-shaped portion 22 of the contact. By rotating the screw 15 the contact is adjusted along the guides 9 in order to insure proper cooperation with the carbon contacts 5 and 6. In the form of contact illustrated, the lower portion of the corner plate 13 serves as a contact surface or face for cooperation with the carbon contacts 5 and 6. The vertical arm of the L-shaped member 8 is also provided with a binding screw 16 which serves to facilitate connecting the said member, and thereby the contact, in an electrical circuit. A vertical screw 19 is threaded into the horizontal portion of the L-shaped member 8, and extends through a cross piece 18, with which it cooperates to clamp the contact in adjusted po-

sition. Adjusting screw 15 is provided with a lock nut 20. The armatures 3 and 4 are in electrical connection with the frame or base 1 through their pivots, and additional
5 connecting means may be provided by wires 23 and 24 secured to the armatures 3 and 4 respectively near their pivots. The other ends of the wires may be secured to the base or frame 1.

10 Referring particularly to Fig. 5, alternating current mains are shown at 30 and 31. One terminal of the coil 7 is connected to one of the alternating current mains 30 by a conductor 33, and the other terminal
15 of the coil 7 is connected to the other alternating current main 31 by a conductor 32. An adjustable condenser 34 is preferably connected in series with the coil 7 and is shown inserted in the conductor 32. The
20 stationary contact is connected by means of conductor 35 to one of the alternating current mains 31, and the frame 1 is connected by conductor 36 to a storage battery or other direct current translating device 37, which
25 in turn is connected through an adjustable rheostat 38 to the other alternating current main 30.

The mode of operation of the rectifying device is as follows:—Reversals of current
30 occur in the coil 7 and an alternating flux is set up in the armatures 3 and 4, thereby making the upper ends of the armatures alternately north and south poles. When the upper ends of the armatures are of north
35 polarity, the south pole of the magnet is strengthened and the north pole weakened, and when the upper ends of the armatures are of south polarity, the north pole of the magnet is strengthened and the south pole
40 weakened. As a result, the armatures are vibrated in synchronism with the alternating current flowing through the coil 7. When the rectifying circuit is closed, current flows from the alternating current main
45 30 through the adjustable rheostat 38, storage battery 37, conductor 36, to the frame of the rectifier, thence through the armatures, carbon contacts and stationary contact to conductor 35, and back to the alternating current main 31. This condition of
50 affairs continues during one half wave of the alternating current. During the succeeding half wave, the circuit is broken between the carbon contacts and the stationary
55 contact. In this manner uni-directional current is supplied to the storage battery or other direct current translating device 37. The adjustable condenser 34 in series with the coil 7 is employed to advance the phase
60 of the current in the coil in order to com-

pensate for the inertia of the armatures and to cause the circuit to be broken at the proper times to avoid sparking. The rheostat 38 is employed to regulate the current supplied to the storage battery 37.

By reason of the considerable mass of the copper plates 12 and 13 and their comb-like structure, the heat generated in the contacts is rapidly distributed through a comparatively large mass of very good conducting
70 metal and is rapidly radiated and dissipated. The temperature of the stationary contact is thus prevented from becoming excessive and the tendency to sparking is materially reduced. As pointed out in my
75 prior application mentioned hereinbefore, the carbon contacts also contribute very materially to this result.

Having now described my invention, what I claim as new therein and desire to protect
80 by Letters Patent is as follows:—

1. In electrical apparatus, a supporting member, a contact adjustably mounted thereon, said contact having a portion co-operating with said supporting member and
85 an upwardly extending recessed portion for radiating and dissipating heat, and means for clamping said contact in adjusted position upon said supporting member, substantially as described.

2. In electrical apparatus, a metallic contact member comprising a substantially U-shaped portion provided with outwardly extending projections at the ends thereof, and plates secured to said projections, said plates
95 having subdivided portions for radiating and dissipating heat, substantially as described.

3. In electrical apparatus, a supporting member having guiding means, a metallic
100 contact member having a portion co-operating with said guiding means, and a plate secured to said portion, said plate having a contact surface and having also portions subdivided for the radiation and dissipation
105 of heat, substantially as described.

4. In electrical apparatus, a stationary contact member and a vibrating contact member adapted to co-operate therewith, the stationary contact member being provided
110 with a heat-radiating and dissipating comb-like extension of substantially greater area than the area of contact surface between said contact members, substantially as described.

This specification signed and witnessed
115 this 10th day of June, 1912.

THOS. A. EDISON.

Witnesses:

HENRY LANAHAN,
ANNA R. KLEHM.