

T. A. EDISON.
SOUND BOX.
APPLICATION FILED MAR. 24, 1911.

1,204,420.

Patented Nov. 14, 1916.

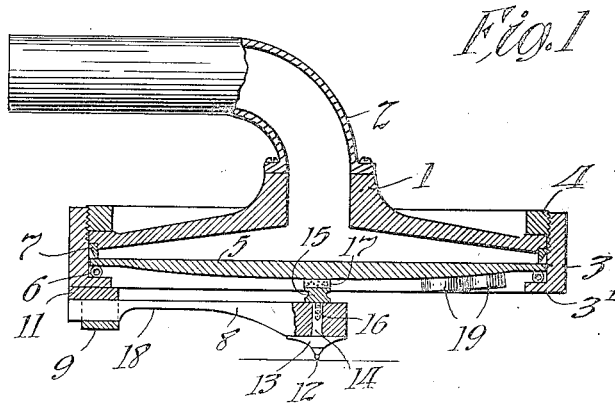
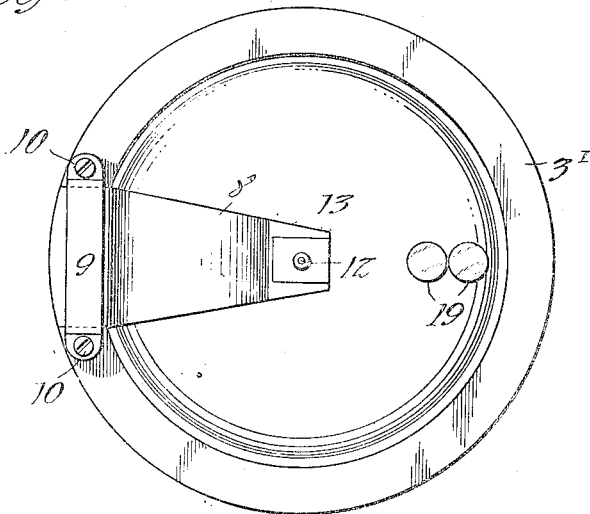

Fig. 2



Witnesses:
Frank D. Lewis
Frederick Bachmann

Inventor:
Thomas A. Edison
by Frank L. How
His Atty.

UNITED STATES PATENT OFFICE.

THOMAS A. EDISON, OF LLEWELLYN PARK, WEST ORANGE, NEW JERSEY, ASSIGNOR TO
NEW JERSEY PATENT COMPANY, OF WEST ORANGE, NEW JERSEY, A CORPORATION
OF NEW JERSEY.

SOUND-BOX.

1,204,420.

Specification of Letters Patent.

Patented Nov. 14, 1916.

Application filed March 24, 1911. Serial No. 616,755.

To all whom it may concern:

Be it known that I, THOMAS A. EDISON, a citizen of the United States, and a resident of Llewellyn Park, West Orange, in the county of Essex and State of New Jersey, have invented certain new and useful Improvements in Sound-Boxes, of which the following is a description.

My invention relates to sound boxes particularly of the type adapted for use in connection with disk records having vertically undulating grooves, although its use is not limited to that type.

The principal object of my invention is to construct a reproducer giving an improved quality of reproduction by the elimination of minute scratch vibrations and by the reduction of the objectionable prominence of high or low notes so as to produce a mellow tone. In conformity with this object, I insert between the stylus arm and the center of the diaphragm a yielding, non-metallic member of short elasticity, preferably of cork, to absorb the scratch vibrations; and in order to balance up the tone, I weight or dampen the diaphragm eccentrically, or between the center and the periphery, preferably by securing thereto one or more disks or buttons of lead or other suitable material. I also prefer to make the stylus arm of wood or other suitable non-metallic substance so as to eliminate the characteristic "ring" or metallic sound which is produced when the common metallic stylus arm is set into vibration.

Other objects of my invention will appear more fully from the following specification and the appended claims.

In order that a clearer understanding of my invention may be had, attention is hereby directed to the accompanying drawing forming a part of this specification and illustrating the preferred form of my invention.

In the drawing, Figure 1 represents a central vertical section through a sound reproducer embodying my invention; and Fig. 2 represents a bottom plan view thereof.

In both of the views, like parts are designated by the same reference numerals.

Referring to the drawings, the body of the reproducer is formed in any suitable manner as by the flat metallic, conical member 1 having secured thereto a hollow neck 2, bent substantially at right angles, the flanged an-

nulus 3, and the threaded ring 4 screwed into the annulus 3 to position and hold the members as shown. The diaphragm 5 is preferably secured between an annular, rubber gasket 6, of circular cross section and a ring 7 preferably of steel formed with a knife edge as shown which is positioned to contact the edge of the diaphragm in a circular line opposite the center line of the annular gasket 6. By reason of this construction, the diaphragm is permitted to bend on the gasket 6 and ring 7 without buckling. I preferably form the diaphragm 5 of wood pulp board making the inner face thereof plane and the outer face thereof except for a short distance from the periphery convex; so that the diaphragm has substantially the shape of a segment of a sphere. This form gives to the diaphragm increased rigidity toward the center and eliminates objectionable local vibrations.

The stylus arm 8 which is preferably made of wood is wedge shaped in horizontal projection and is rigidly secured at its broad end to the member 3 by a bracket or saddle 9 held in place on the horizontal flange 3' of the member 3 by screws or other fastening means 10. A strip 11 of metal or other suitable material is interposed between the stylus arm and the flange 3' so as to space the said arm a proper distance from the diaphragm and is held in place by the bracket 9. The stylus arm 8 extends substantially parallel to the diaphragm to the center thereof under which last named point it supports a stylus 12 which is secured to the center of the diaphragm in the following manner. The stylus, which is preferably a diamond, is mounted in a metallic holder 13 having a flat portion engaging the under side of the arm 8 and a reduced shank 14 extending through and fitting into an opening in the said arm. A screw 15 provided with a threaded shank 16 engages the upper side of the arm 8 and is screwed into the shank 14 to secure the stylus holder in place. A piece of cork or other yielding, non-metallic material 17 of short elasticity is interposed between and secured preferably by shellac or other suitable adhesive to the member 15 and the center of the diaphragm. In order to make the arm 8 resilient in the direction of the movement of the stylus 12, that is, at right angles to the record surface, the lower surface thereof is preferably con-

caved intermediate its ends as shown at 18 so that the cross section of the intermediate portion of the arm is materially decreased. With this construction, the stylus is held firmly in contact with the record groove so that the record is faithfully reproduced, the wedge form of the said arm preventing lateral play of the stylus. Also by reason of the employment of the cork insert 17, a large amount of the minute scratch vibrations ordinarily emitted when the stylus is tracking a record is absorbed.

In order to balance the diaphragm to reduce the objectionable prominence of the very high and low notes which tend to throw false waves on the diaphragm by excessive amplitude, the diaphragm is loaded or weighted eccentrically, or between its center and periphery. This is preferably accomplished by securing to the diaphragm by shellac or other suitable adhesive one or more weights 19 preferably of lead concentrated at a single position on the diaphragm. When the diaphragm is thus loaded, the vibration of the weighted portion thereof is checked or dampened; so that, as the movements of the stylus are applied to the center of the diaphragm, or eccentrically to the unweighted or freely movable portion thereof, the diaphragm is not in tune with and does not give undesirable prominence to any particular note. The dampening of the vibrations of the diaphragm by the weights also produces a soft mellow tone. The weights produce substantially no bracing effect upon the diaphragm.

While I have shown the preferred embodiment of my invention, many changes may be made in the structure disclosed without departing from the spirit of my invention.

What I claim as new and desire to protect by Letters Patent of the United States is as follows:

1. The combination of a stylus, a diaphragm, means maintaining said stylus in operative relation to said diaphragm and means for weighting said diaphragm, said weighting means being located entirely to one side of the center of the diaphragm and substantially at a single position on the diaphragm.

2. In a sound reproducer, the combination of a support, a diaphragm supported thereby, said diaphragm having weighting means

located eccentrically thereof and substantially at a single concentrated position thereon, and a reproducer stylus connected with the center of said diaphragm, substantially as described.

3. In a sound reproducer, the combination of a support, a diaphragm supported thereby, said diaphragm having weighting means located eccentrically thereof and substantially at a single concentrated position entirely to one side of the center of the diaphragm, and a reproducer stylus connected with the center of said diaphragm, substantially as described.

4. An acoustic diaphragm having means for weighting while permitting substantially free flexure of the same, said means being applied to the diaphragm at a single concentrated position to one side of the center of the diaphragm, substantially as described.

5. In a sound reproducer, the combination of a diaphragm, a reproducer stylus connected to the center thereof, and means for weighting while permitting substantially free flexure of the diaphragm, said means being applied to the diaphragm at a single concentrated position to one side of the center of the diaphragm, substantially as described.

6. In a sound reproducer, the combination of a support, a diaphragm supported thereby, said diaphragm having weighting means located eccentrically thereof and substantially at a single concentrated position thereon, a reproducer stylus, and means comprising a yielding non-metallic device for transmitting the vibrations of the stylus to the center of the diaphragm, substantially as described.

7. The combination of a stylus, a diaphragm, means maintaining said stylus in operative relation to said diaphragm, and means comprising a button for weighting said diaphragm, said weighting means being located entirely to one side of the center of the diaphragm and substantially at a single concentrated position on the diaphragm, substantially as described.

This specification signed and witnessed this 22nd day of March, 1911.

THOMAS A. EDISON.

Witnesses:

FREDERICK BACHMANN,
ANNA R. KLEHM.